

**PROCUREMENT OF MOBILE DISPENSING UNITS FOR DOOR DELIVERY
PROGRAMME UNDER PUBLIC DISTRIBUTION SYSTEM THROUGH
GOVERNMENT e-MARKETPLACE (GeM) – ONLINE PORTAL OF
GOVERNMENT OF INDIA**

I. General Terms and Conditions of GeM:

1. Introduction

This document is an electronic record published by GeM under the provisions of the Information Technology Act, 2000 and the rules made there under (as applicable) and shall act as valid agreement between Seller / Service Provider and Buyer. Further the use of GeM Portal for Sale / Purchase of Goods / Services and the **resulting Contracts shall be governed by the following General Terms and Conditions (GTC) (unless otherwise superseded by Product / Service specific Special Terms and Conditions (STC), Product / Track / Domain Specific STC of Particular Service including its SLA (Service Level Agreement) and BID/Reverse Auction Specific Additional Terms and Conditions (ATC) as applicable).**

Government e-Marketplace (GeM) is the National Public Procurement Portal; an end- to-end online Marketplace for Central and State Government Ministries / Departments, Central & State Public Sector Undertakings (CPSUs & SPSUs), Autonomous institutions and Local bodies, for procurement of common use goods & services. The portal is owned and managed by GeM SPV which is a Section 8 (Non- Profit) Company registered under the Companies Act, 2013. GeM SPV operates, monitors and supervises all the business transactions on the portal through the Managed Service Provider as per defined roles and responsibilities.

2. General Terms and Definitions:

- a. **“APPLICABLE LAWS”** shall mean any statute, law, ordinance, notification, rule, regulation, judgment, order, decree, bye-law, approval, directive, guideline, policy or other governmental restriction as may be in effect.
- b. **“GOODS”** shall mean an Article / product or an intangible product like

software, technology transfer, licenses, patents or other intellectual properties being offered for sale on the GeM portal by Seller(s) on GeM. The term 'Goods' shall also include works and services which are incidental or consequential to the supply of such goods, such as, transportation, insurance, installation, commissioning, training and guarantee / warranty obligations as defined in the scope of supply given in the contract.

- c. **“SERVICES”** shall mean the services offered or provided by the Seller such as IT Professional Services, Manpower Services, Security Services, Transport Services, etc. listed as Services on GeM. The term 'Service' shall also include supply of goods / articles which are incidental or consequential to the provisioning of such Services as defined in the scope of supply given in the contract.
- d. **“SERVICE LEVEL AGREEMENT (SLA)”** shall mean the Contractual Commitment that prevails between the Buyer and the Service Provider with regard to type of service to be provided, deliverables, desired performance level, reliability and responsiveness, monitoring process and service level reporting, response and issue resolution time-frame, repercussions / penalties / remedies for service provider not meeting its commitment. The SLA of a particular contract may carry the matrix regarding the delivery of the goods and/or services and the corresponding penalties or remedies and liquidated damages as applicable.
- e. **“CATEGORY SPECIFICATION”** shall mean the framework of technical features, functional capabilities, technical properties, certifications of the items etc. in a particular category. The Specifications shall identify the key parameters defining the products with all necessary validations related to configuration, type of data, restrictions, range / allowed values, allowed units etc. Sellers as well as Buyers while offering / buying the Goods / services shall have to comply with the validation rules / restrictions provided for in the Category Specification. Buyers / Sellers can not add parameters and / or drop down values not provided for in category Specification. If any Buyer / Seller desire to add new parameter, value, validation etc. against any category specification, they have to raise request for the same to GeM for incorporation in Category Specification.

f. **“BUYER”** is the Contract placing authority, which includes Central/State Government Ministries/Departments including its attached/subordinate offices, Central/State Public Sector Units (PSUs) and Autonomous Bodies acting through its authorized officer(s) for and on behalf of President of India/Governor of the State /PSU/Autonomous Bodies, as the case may be, for purchase of Goods/Services offered by Sellers on GeM.

g. **“SELLER / SERVICE PROVIDER”** on GeM shall mean any legal entity such as firm(s) of Proprietorship / Partnership Firm / Limited Liability Partnership / Private Limited / Limited company / Society registered under Society’s Act / Statutory Bodies etc., registered on GeM to sell its Good(s) / Service(s) to the Buyers registered on GeM.

The “Seller on GeM” will be either OEM (Original Equipment Manufacturer*) or Seller having authorization to sell products manufactured by the OEM in open market.

* OEM is the owner of the Brand / Trademark of the product being offered or in case of un-registered brand’s products / products with own brand, the actual manufacturer of the final product.

In case of Services related to Goods, Service Provider on GeM will be either OEM or Service Provider having authorization to Service products manufactured by that OEM in open market. In respect of other Services, Service Provider on GeM will be any legal entity offering its services.

By registering on GeM portal , Seller / Service Provider hereby agrees to be bound by these General Terms and Conditions for Sale / Purchase of Goods and / or Services (GTC); Product / Service Specific Special Terms and Conditions (STC) and Service Level Agreements (SLAs) for various Services; and Additional (Bid Specific) Terms and Conditions (ATC) as applicable.

For the purpose of this document and transactions on GeM, Seller as well as Service Provider will be referred to as “Seller”

h. **“USER ID and PASSWORD”** All users including Buyers and Sellers (primary as well as secondary) will get User ID and Password created on GeM following due registration process defined on GeM. It is the responsibility of

the user to keep their User ID and Password secure and confidential. Individual user shall be solely and completely responsible for all transactions taking place on GeM portal using his / her User Id and Password and GeM shall not be responsible in any manner.

- i. **“LICENSE”** shall mean by registering the Seller and by offering Product / Service details on GeM, the Seller grants GeM a non-exclusive, royalty-free, irrevocable, perpetual and fully sub-licensable right to use, reproduce, modify, adapt, publish, translate, distribute, and/or display the content/materials which has been submitted to GeM excluding Aadhaar No. In case of registration of Primary user and creation of secondary user(s) by the Buyer/Seller, their Aadhaar (UID) details collected by GeM are solely for user verification and to apply e-signing on the documents. The e-sign is at par with digital signatures as per Information Technology Act Amendment 2008 and it works based on details available in Aadhaar database of UIDAI and there is no interference / intrusion in their personal details.
- j. **“CONTRACT”** shall mean the purchase order created / issued by the Buyer on GeM for supply of Goods / Services in electronic form which includes scope of supply, delivery instructions and specifications etc. as ordered by Buyer against such Contract besides the subject GTC, STC/ATC as the case may be.

3. Role, Responsibilities and Obligations of Seller/ Buyer:

A. Role and Responsibilities of Sellers on GeM are as under:

- i. Only Director (s) / Partner (s) / Proprietor (as applicable) are authorized to become Primary User and register any legal entity on GeM as Seller.
- ii. Once Seller/Service Provider is registered and account is created on GeM, the Primary user of the Seller/Service Provider can create Secondary User Accounts within Seller/Service Provider Organization with different Roles and Responsibilities. However, the Primary User creating Secondary User accounts shall continue to be fully responsible and accountable for all actions / transactions done by Secondary Users on GeM Portal.
- iii. Since GeM is a trust based Portal, the complete accuracy and integrity of data submitted in respect of the Seller and also in respect of the Goods /

Services offered on GeM will be the sole responsibility of the Seller/Service Provider. Seller will be liable for administrative action as per GeM terms and conditions in case of any discrepancy / infirmity in any data / information submitted on GeM.

- iv. The Primary / Secondary Users of Sellers, offering Goods/Services and/or participating in e-Bidding / Reverse Auction on GeM, must ensure that they have the requisite authorization to enter into contract with Buyer(s) in GeM for and on behalf of the Seller, failing which such Seller as well as the individual(s) shall be vicariously liable for its actions and also for any liability arising out of such actions.
- v. Seller can offer any number of products. However, it will be the sole responsibility of the seller to satisfy themselves regarding possessing the requisites for doing business for the offered product(s). The Sellers are solely responsible for ensuring that there is no violation of any Intellectual Property Rights in their offer for sell / providing service on GeM.
- vi. The Seller should not exercise any corrupt influence on any aspect of contract and commit to take all measures necessary to prevent corruption maintaining complete transparency, integrity and fairness in all activities related to GeM.
- vii. The seller would represent its business on the GeM portal and is mandated to comply with all the terms and conditions of the platform. Sellers would be solely and absolutely responsible for the information provided about their organization, business, products and services on the portal and would be required to produce proof of such information, if requested at any point in time by the Buyer and / or GeM.
- viii. GeM would not allow creation of any fresh data related to Seller identity on GeM portal. All details provided by the Seller at the time of registration would be counter checked / verified through other data bases of Government such as PAN, MCA 21, Udyog Aadhaar etc. For Financial details, PAN / Income tax Database shall be primary validating database and will override any conflicting data in any other database. If the data / details entered by the seller while registering on GeM is not verified with

validating databases, registration will not be allowed. Further, in case of any conflict in details after registration, Seller's registration would be automatically suspended. It is the Seller's responsibility to keep all their information on GeM updated with the latest change(s). Non-updating of details on GeM within 7 days of such occurrence would make Seller liable for administrative actions.

- ix. Eligibility of Sellers in terms of Turn Over / Past Performance / Profitability etc. and also their eligibility for availing various benefits / advantages in terms of various Govt. Policies / Guidelines / Acts / Laws etc. shall be determined solely on the basis of data fetched / validated or verified through external agency / owner of that set of database such as Income Tax / PAN Data Base, MCA 21, Udyog Aadhaar, GSTN, Certifying Agencies such as BIS, BEE etc. In case of any discrepancy in data available in these databases, Seller has to get the same updated in the corresponding validating database before updating the same on GeM. Till such time only the existing validated information shall be used to decide seller's eligibility on GeM. Any default in sellers updating their data on partner sites / validating databases and any fall out of the same impacting adversely any transaction on GeM, shall entirely and exclusively be Seller's responsibility. GeM shall not be responsible for any consequential impact on any GeM transaction due to data discrepancy and / or suspension of seller account due to data discrepancy. Seller will be solely responsible for the same.
- x. The Seller shall be solely responsible for the Goods / Services including, without limitation, the applicable guarantee / warranty, shelf-life, quantity, quality and the title and for giving the correct and accurate details of the offer their Goods and / or /Services indicating product specifications, quantity which can be supplied over the specified time period, etc. as per catalogue or catalogue based template prescribed in GeM. Seller would ensure that the Goods or /Services offered are latest, new and complete in all respects. Where Seller is selling any Goods which needs spare parts, Seller should ensure and make available such spare parts for a minimum period of three years from the date of expiry of warrantee period (unless

otherwise specified). The individual Sellers shall ensure that the products offered in e-Bidding and/or ordered shall remain available on GeM during the bid / contract validity period.

- xi. Sellers shall offer minimum discount of 10% on the Maximum Retail Price (MRP) mandatorily (unless otherwise specified for offering their products on GeM). Sellers are free to offer higher discounts. The Seller must offer its best possible lowest price on GeM and undertake that it would not sell or offer to sell the same product outside GeM in comparable quantity on similar terms and conditions at a price equal to or lower than Offer Price on GeM. In case any such infringement by Seller is noticed, the Seller shall be liable to be removed / debarred from the GeM.
- xii. By offering their product on GeM, the Seller agrees for sharing price details of the offered Goods / Service by GeM authorities with other Government agencies including Department of Excise & Customs, Income tax, GST etc.
- xiii. Listing of Goods / Services in irrelevant / inappropriate categories is strictly prohibited. If any such infringement made by Seller leads to placement of a contract by any Buyer for such inappropriately offered product(s)/service(s) by the Seller, such contract shall be treated as null and void. No claim whatsoever against such contract shall be admissible and entertained.
- xiv. The Seller(s) shall pass on all the benefits associated with any scheme / offer / freebies provided by the OEM on any product from time to time on an "as-is basis" to the Buyer. This obligation will also apply to OEM's directly supplying the goods. Holding back any such offer or accounting such freebies in quantity supplied shall make such consignments liable to be rejected by the consignee and shall also be considered as inappropriate and against the GeM policies for which GeM reserves all rights to take necessary action against such Seller/OEM as deemed fit.
- xv. By registering on GeM and by participating in any bid on GeM, Seller undertakes that presently it is not "Debarred from Bidding" on the

grounds mentioned in Rule 151 of GFR 2017.

B. Role and Responsibilities of Buyer on GeM:

Buyer Registration on GeM is divided in two categories:

a. **Primary User:** In GeM , the Primary User is as under:

- i. Any officer of Central / State Government / PSU / Autonomous Bodies / Local Bodies / Constitutional Bodies / Statuary Bodies at the level of Deputy Secretary of the Government of India or equivalent
- ii. Head of the Office at Sub Centre / Unit / Branch, can Register his / her organization / unit on GeM portal as Primary User.

Primary User shall be responsible for registering the organization on GeM, for creating User accounts for Secondary Users, assigning them roles and responsibilities on GeM and for supervision of all transactions performed by Secondary Users under him / her.

Primary User shall also be vicariously responsible for ensuring compliance of General Financial Rules and / or Rules Governing Public Procurement in respect of their organization, all GeM terms and conditions and other Procurement Policies / Guidelines notified by the government from time to time, by all the secondary users including timely payments and for dispute resolutions as per GeM terms and conditions.

Primary user cannot perform any Procurement related transactions on GeM portal.

b. **Secondary Users:** Secondary Users are officials responsible for procurement transactions on GeM including Placement of Contracts, Receipt of Stores, and Payments to the Sellers etc. The access rights permissible to registered Secondary users would be decided by the Primary User of the Department. Secondary Users may be given the roles of Buyer / Consignee / Drawing and Disbursement Office (DDO) / Paying Authority etc. For transaction on GeM portal, Buyer is the official who is responsible for processing procurement transaction up to Order Placement stage.

Consignee is the Secondary User in Buyer Organization responsible for certifying receipt and acceptance of the goods procured.

Buyer's responsibilities on GeM portal are as under:

- i. The Buyers are responsible to ensure that the procurement done by them are in compliance of General Financial Rules and / or Rules Governing Public Procurement in respect of their organization, all GeM terms and conditions and other procurement Policies / Guidelines notified by the government from time to time, including timely payments as per GeM terms and conditions.
- ii. The Buyers (in all capacities i.e. as Buyer, Consignee, DDO, Paying Authority etc) are responsible to ensure that the procurement done by them are in compliance with GeM Terms and Conditions / Guidelines and all contract related transactions are completed within time lines prescribed in GeM Contract.
- iii. The Buyers must ensure that they have the requisite authorization to enter into contract with Seller(s) on GeM for and on behalf of the organization, failing which such individual(s) shall be individually liable for its actions and also for any liability arising out of such actions.
- iv. While making procurement on GeM, the Buyers shall judiciously search and shortlist items using filters such as quantity, technical parameters, delivery period, warranty period, consignee location(s), Seller's eligibility etc. as per their approved requirements. Placement of contract for a product / service uploaded by the Seller in any wrong/inappropriate product category is strictly prohibited and such contracts shall be treated as null and void and such Buying shall adversely affect Buyer Rating on GeM.
- v. The Buyers shall satisfy themselves that the price of the selected offer is reasonable. Buyer is at liberty to utilize all the data / information and Business Analytics made available in GeM including e-bidding and reverse auction.
- vi. The Buyers, before placing the order on GeM, should have the required mandatory approval with prior sanction and approval of the

competent authorities and shall be in compliance with and as per procedures outlined in GFR and other procurement guidelines issued by the Government from time to time.

- vii. On award of the Contract(s), it would be construed that the Buyer has obtained all necessary Administrative & Financial sanctions of the competent authority and adequate funds are available indicating the relevant Head of accounts in the awarded Contract(s).
- viii. The Buyers should not exercise any corrupt influence on any aspect of contract and commit to take all measures necessary to prevent corruption maintaining complete transparency and fairness in all activities related to GeM.
- ix. Buyers are not allowed to place any order at GeM prices outside GeM. The prices on GeM are only applicable if the procurement is made through GeM portal. Using GeM prices for procurement outside GeM portal is strictly prohibited. Further, Buyers are not allowed to place any off-line contract to the Seller directly based on the outcome of e-Bidding / RA conducted on GeM. All such contracts shall be treated as null and void and GeM reserves the right to delete all data related to such transactions from GeM database besides taking suitable actions against such Buyers including suspension from GeM and / or reduction of Buyer rating etc.

4. Enabling provisions of Rule 149 of General Financial Rules- 2017

Enabling provisions of Rule 149 of General Financial Rules- 2017 as amended vide Ministry of Finance OM dated 02.04.2019 regarding procurement through GeM and necessary guidelines and terms and conditions thereon:

GeM portal may be utilized by the Government buyers for on-line purchases as under:-

- i. Up to Rs.25,000/- through any of the available suppliers on the GeM, meeting the requisite quality, specification and delivery period.
- ii. Above Rs.25,000/- and up to Rs.5,00,000/- through the GeM Seller having lowest price amongst the available sellers (excluding Automobiles where limit of Rs.30,00,000/- will be applicable), of at least three different

manufacturers, on GeM, meeting the requisite quality, specification and delivery period. The tools for online bidding and online reverse auction available on GeM can be used by the Buyer if decided by the competent authority.

- iii. Above Rs.5,00,000/- through the supplier having lowest price meeting the requisite quality, specification and delivery period after mandatorily obtaining bids, using online bidding or reverse auction tool provided on GeM (excluding Automobiles where limit of Rs.30,00,000/- will be applicable).
- iv. The Government Buyers may ascertain the reasonableness of prices before placement of order using the Business Analytics (BA) tools available on GeM including the Last Purchase Price on GeM, Department's own Last Purchase Price etc.
- v. GFR rule 149 allows direct on-line purchases on GeM up to Rs. 25,000/- through any of the available suppliers on the GeM, meeting the requisite quality, specification and delivery period. However this is subject to procuring authorities certifying the reasonability of rates. While making such direct on-line purchase below Rs. 25,000/-, the buyer should have approval of competent authority and should also record reasons for selecting the specific product in case lowest priced products are not being accepted / ordered.
- vi. Tools have been deployed on GeM portal to show the price of compared products on other e-commerce sites (wherever available) and also the rates at which orders have been placed on GeM for such items in recent past. While taking decision on reasonableness of price, the buyers may also take into account the discount over MRP; Last Purchase Price on GeM, Department's own Last Purchase Price; rates on other e-commerce websites etc. The prices on e-commerce site give a broad idea and its terms and conditions may be different. If it is found that the price available on GeM marketplace is not reasonable or is substantially higher than e-commerce sites or LPP, the GeM Portal provides tools for online bidding or reverse auction which can be used by the Buyers to get better competitive rates and then satisfy themselves about reasonableness of the price as per GFR -2017 before placement of contract. Bidding should be considered as the preferred mode of procurement above Rs.

25,000/-.

- vii. In case of Direct Purchase, during carting period, rates for carted quantity, for that buyer, are frozen for carting period as notified from time to time on GeM against any upward revision by seller. However, advantage of any downward revision in the offer price of carted item shall be automatically provided to the buyer.
- viii. According to the provisions of Rule 149 (ii) of GFR, 2017, GeM shall be utilized by Government buyers for direct on-line purchases above Rs. 25,000/- and up to Rs. 5,00,000/- however such purchase has to be through the Seller having the lowest price (L-1) amongst the available Sellers on the GeM. In order to ensure that buyers select only L-1 available offer, the GeM portal requires that buyer first compares all the product options available on GeM to ensure that it meets its requirements/ specifications. While comparing, care should be taken that comparison has to be done between products of at least three different Manufacturers / OEMs. For L-1 buying, comparison has to be made between products of at least three different OEMs. If Buyer wants to buy any specific OEM's product then he has to go for Proprietary Article Certificate (PAC) buying after obtaining necessary approvals of competent authorities for PAC buying as per GFR-2017.
- ix. **Proprietary Article Certificate (PAC) Buying:** While making procurement under PAC Buying on GeM, Buyer has to comply with following conditions:
- (a) In case a Govt. Buyer on GeM wants to make procurement on proprietary basis on the GeM Portal after obtaining the requisite approvals / PAC certificate from their competent authority as per Rule 166 of GFR-2017, the Buyer can use PAC filter provided on GeM for selecting a specific model/ make available from a particular GeM Seller. As per GFR, Proprietary Article Certificate in the following form should be available with Buyer before procuring the goods under PAC Buying:
- (i) The indented goods are manufactured by M/s.
- (ii) No other make or model is acceptable for the following reasons:

(iii) Concurrence of Finance wing to the proposal vide:
.....

(iv) Approval of the competent authority vide:

(b) The Seller's price on the Portal is just their offer prices and the proper discovery of price generally happens through bidding/RA. Moreover, in PAC procurement irrespective of multiple listing by authorised sellers, the important issue of price control remaining with the OEM cannot be overlooked. Therefore, in case of all the PAC procurements, the Buyers will have to carry out extra due diligence in establishing the reasonableness of prices before placement of contract as per Para (vii) of Rule -149 of GFR-2017.

(c) Except for direct buying up to Rs. 25,000/- subject to establishing the reasonableness of price, the bidding will be mandatory for procurements above Rs. 25,000/-. As result of bidding, the response could be as under:

- i. Only OEM is available or only single authorised seller is available.
- ii. OEM as well as multiple authorised Sellers are available.
- iii. Multiple authorised Sellers of the OEM are available.

(d) After bidding, under PAC buying, the Buyer may take decision with the approval of the competent authority to process the procurement subject to establishing the reasonableness of prices before placement of contract as per Para (vii) of Rule - 149 of GFR-2017.

x. In order to give flexibility to the buyers in sourcing their requirements through GeM, provision has been made in e-bid and RA modules for indicating delivery period in terms of "number of days from date of placement of contract". While stipulating delivery period in their bid documents, Buyers are advised to be careful since un-realistic delivery period stipulations may result in elimination of some genuine sellers, lack of competition and may ultimately have impact on cost of procurement. While

fixing delivery period in e-bid/ RA bid, buyers should not only take into consideration the quantity required and the essentiality of requirement of that quantity within stipulated time period but also the possible impact of shorter delivery period on competition in e-bidding / RA.

- xi. Splitting of demands by creating multiple Bids / RAs of same goods / services or making repeated procurements of same Goods / Services through L-1 buying as per rule 149(i) and 149(ii) of GFR-2017 are strictly prohibited on GeM. Splitting of demand deprives the organizations from achieving the best competitive prices leveraging economies of scale. It also implies avoiding the necessity of obtaining the sanction of higher authority required with reference to the estimated value of the total demand. It is a violation of Para Rule 149 (viii) of GFR -2017 and terms and conditions of GeM Portal and Buyer including the Primary Buyer shall be entirely responsible for the same. If any such splitting of demand is noticed, GeM shall have the right to take necessary action such as blocking of such Bids/RAs and / or cancelling such contracts.
- xii. GeM is a dynamic online marketplace. The product/service listings across the existing categories are dynamic. Moreover, new categories of products/services are continuously being added on GeM. In situations where there is only one offer available in a product/ service category and/or there is offer from only one Seller after filter based search, the buyer should not select such offer for buying. Efforts should be made by Buyer to get their past suppliers and prospective Sellers on-boarded on GeM so as to ensure availability of sufficient Sellers on GeM. This however will not apply for PAC procurement.

xiii. e-Bidding and Reverse Auction (RA) on GeM

- (a) The e-Bidding / RA module of GeM is a tool provided to the Buyer(s) for organizing bidding / RA from GeM Sellers of the particular product category for a pre-defined requirement i.e. quantity, technical parameters for Goods/ Services of the particular product category required for one or more Buyers / Consignees.
- (b) Prior to initiating e-Bidding / RA, the Buyer shall judiciously search and shortlist item among the items offered on GeM

using filters such as quantity, technical parameters, warranty period, consignee location(s) etc. as per the requirement. In case the search made using actual quantity required, fails to identify sufficient offers, the Buyer may use an indicative quantity for initial search and selection of product and quantity may be amended to match the actual requirement at the time of finalizing e-Bidding / RA.

- (c) The technical parameters and warranty of the item identified by the Buyer shall be base parameters of the item for conducting e-Bidding / RA for the required Goods/Services.
- (d) The e-Bidding / RA document will be finalized by the Buyer(s) by stipulating requirements such as Quantity, Consignee Details, Terms of Delivery, Delivery Period, EMD, Performance Bank Guarantee, Time & Date for Start and End of Bid Submission and for Opening of Bids and required Bid Validity period etc. GeM system shall decide Start / Reference Price and Step Value of Decrement in case of RA based on product selection and / or outcome of bidding process.
- (e) Bid Life Cycle: Bid Life Cycle is the period within which a buyer has to complete the entire life cycle i.e. technical evaluation, financial evaluation and order creation of Bid process. By default, it is 90 days from the date of Bid publication. This can be configured to 120 / 150 or 180 days in exceptional cases through catalogue Management System (CMS) for a particular product category (not for a particular Buyer or Bid).
- (f) The e-Bidding / RA invitation / Notice shall be published on GEM, stipulating the last date for bid submission / opening of bids giving at least clear 10 days time after the publication. Any change in last date for bid submission will be intimated to eligible bidders through e-mail / GeM. The e-Bidding invitation shall be extended to all the registered Sellers on GeM who have Goods / Services for that particular category listed on GeM, at least 2 hours prior to closing time of e-Bidding / RA. The GeM normally requires 48 hrs for approval / rejection of the product / service offered by Sellers before it is listed on the portal. Considering these time lines, the Sellers are required to offer their Goods / Services on GeM

well in advance before bid closure. The decision of the Buyer/GeM regarding technical/commercial eligibility of the individual Seller to be invited for e-Bidding / RA shall be final.

- (g) The Seller participating in the e-bidding / RA may offer any one of their product(s) already listed on GeM. The bid submitted under e-Bidding / RA shall remain valid for 15 days (or as stipulated by the Buyer in the bid document) from the Bid Opening Date (till 24.00 Hrs IST). Bid Validity can be further extended with mutual consent between Buyer and Seller subject to the condition that total Bid Life Cycle cannot go beyond the stipulated time limit as per GeM CMS. The products offered in e-Bidding / RA can not be withdrawn by the Sellers from GeM during the bid validity period. The Buyer reserves the right to postpone/cancel the e-bidding and intimation thereof will be sent by e-mail / GeM to the Bidders. Any amendment / corrigendum to the e-bid invitation issued by the Buyer will be made online and shall be uploaded on the GeM. The participation by the Seller in e-bidding shall be construed as his / her acceptance for all the Terms and Conditions as outlined in the e-bidding including GTC, STC and ATC. However, the Buyer shall have right to decide the technical and commercial acceptability of the individual bids based on eligibility criteria and compliances as stipulated in the bid document. The technical parameters shown in the bid are from a particular catalogue as selected by the buyer while applying initial filters in selection of the product. The sellers are free to bid for same, equivalent or superior specifications catalogue / products. In the public interest, buyers will evaluate such bids based on their requirements / end use and bid parameters and will accordingly technically accept or reject the bids on merits.
- (h) In bid documents, Buyers can incorporate suitable eligibility criteria and additional terms and conditions only using various filters and ATC module available in e-bidding / RA modules of GeM. Buyers are not allowed to incorporate eligibility criteria and / or additional / special terms and conditions exterior to the GeM portal by making reference to any other website / documents etc.

- (i) In case, two or more acceptable bidders are found to have quoted identical lowest bid price, Buyer has to conduct Reverse Auction for the required Goods among all technically qualified bidders in case of bids for Goods. In case of Services bids, if the multiple L-1 bidders have quoted the lowest allowed price for that service, Buyer shall have two options for placement of Contract:
- a) Placement of contract by selection of an agency from amongst the L-1 bidders through a Random Algorithm run by GeM system.
 - b) Placement of contract on any one of the L-1 bidders based on any criteria as deemed fit by the Buyer with appropriate internal approvals
- (j) The Buyer reserves the right to accept/reject any bid including the lowest bid received through e-bid and/or annul the e- bidding process.
- (k) The participating bidders shall not disclose details of their bids or other details of their e-bids to other bidders or indulge in any anti-competitive behaviour including price manipulation in violation of Competition Act, 2002.
- (l) The Buyer/GeM will not be held responsible for consequential damages such as no internet connection, no power supply, system problems, loss of electronic information, power interruption etc.
- (m) Against any bidding or RA conducted on GeM, if a bidder quotes Nil Charges/consideration, the bid shall be treated as non-responsive and will not be considered.
- (n) There shall be no EMD for Bids / RA having estimated value less than Rs. 5 lakh. For bids / RA having estimated value more than Rs 5 Lakh, while finalizing e-Bid / RA, Buyer shall indicate the exact amount of EMD required to be submitted by bidders in the form of Bank Guarantee on GeM portal in the prescribed format. Scanned copy of the same shall be uploaded by Seller in the online bid and hard copy of the same will have to be submitted directly to the Buyer within 5 days of bid opening. GeM recommends quantum of EMD @ 1% of estimated value of procurement. The Buyer also has the option to select EMD between 0.5% to

5%. The same should be valid for 45 days beyond the bid validity. Following categories of Sellers shall however, be exempted from furnishing EMD:

- i. Micro and Small Enterprises who are manufacturer of the Primary Product Category or Service Provider of the Primary Service Category and give specific confirmation to this effect at the time of bid submission and whose credentials are validated online through Udyog Aadhaar and through uploaded supporting documents.
- ii. Start-ups as recognized by Department of Industrial Policy and Promotion (DIPP).
- iii. KVIC, ACASH , WDO, Coir Board, TRIFED and Kendriya Bhandar.
- iv. Sellers who have got their credentials verified through the process of Vendor Assessment by Vendor Assessment Agencies for the Primary Product / Primary Service for which Bid / RA has been invited.
- v. Sellers/ Service Provider having annual turnover of Rs 500 Crore.
- vi. Micro and Small Enterprises registered with NSIC for the Primary Product Category whose credentials are validated through NSIC database and through uploaded supporting documents.
- vii. Micro and Small Enterprises registered with DIC for the Primary Product Category whose credentials are validated through DIC database and through uploaded supporting documents.
- viii. Sellers / Service Providers holding BIS License for the Primary Product Category whose credentials are validated through BIS database and through uploaded supporting documents.
- ix. Central / State PSUs.
- x. Seller / Service Provider registered with designated Agency / Authority as specified in the bid document by the Buyer – such bidder shall have to upload scanned copy of relevant registration document in place of EMD document while bidding.

- (o) EMD submitted by the bidder shall be forfeited, if the bidder:
- i. Withdraws or modify or impairs or derogates from the bid in any respect within the period of validity of its bid; or
 - ii. If it comes to notice that the information / documents furnished in its bid is false, misleading or forged; or
 - iii. Fails to furnish requisite performance security / PBG within stipulated time required as per e-bid / RA conditions.
- (p) Notwithstanding above, GeM SPV / GeM Admin also reserve the right to debar such seller from GeM portal. Such debarment shall be for minimum 3 months initially on first such offence and on repeat offence, the debarment period can be increased suitably by GeM SPV / GeM Admin. By submitting a bid on GeM, the Bidder explicitly undertakes to abide by the above clause.
- (q) Earnest money of unsuccessful bidders shall be returned within 15 days after the award of contract or expiry of bid validity whichever is earlier. Earnest money of successful bidder shall be returned within 15 days after receipt of Performance Security / e-PBG.
- (r) In case of RA, Start / Reference Price and Step Value of Decrement shall be indicated to the Bidders at the start of the auction. Any participating bidder can bid one or multiple Step Decrement lower than the prevailing Lowest Bid at that time.
- (s) The Bidder shall be able to view Bid Start Price, Bid Decrement Value, Prevailing Lowest Bid value and last Bid Placed by him. Whenever a lower price bid is received in the closing moment i.e. within 15 minutes of existing end time of Reverse Auction, the end time of reverse auction shall be extended automatically by another 15 minutes. All participant sellers of that RA shall be notified by the GeM system about extension of time through email and/or SMS and they shall be allowed to submit revised bid under the RA. The same process shall be repeated, if there is another lower bid received in the RA during last 15 minutes of RA.
- (t) GeM / Buyer shall not have any liability to bidders for any interruption or

delay in access to the GeM site / Reverse Auction link etc, irrespective of the cause.

(u) By creating a bid on GeM, the Buyer undertakes as under:

"I confirm that this tender document complies with the "Public Procurement (Preference to Make in India) Order, 2017" issued by DIPP and "Public Procurement Policy for Micro and Small Enterprises (MSEs) Order, 2012" issued by MoSME".

(v) **Bid to RA:** While creating bid on GeM, Buyer shall have the provision to select Bid to RA option. If this option is selected by the Buyer at the time of bid creation, Sellers would be required to submit their Technical and Commercial bids before bid closure. After completion of technical evaluation by the Buyer, Reverse Auction would be conducted amongst first 50% of the technically qualified bidders arranged in the order of prices from lowest to highest. Number of sellers eligible for participating in RA would be rounded off to next higher integer value if number of technically qualified bidders is odd (e.g. if 7 bids are technically qualified, then RA will be conducted amongst L-1 to L-4). In case number of technically qualified bidders are 2, RA will be between both without any elimination.

In case Primary products of only one OEM are left in contention for participation in RA based on lowest 50% bidders qualifying for RA, the number of sellers qualifying for RA would be increased to get at least products of one more OEM (directly participated or through its reseller) if available. Further, if bid(s) of any seller(s) eligible for SME preference is / are coming within price band of 15% of L-1 or if bid of any seller(s) eligible for Make in India preference is / are coming within price band of 20% of L-1, then such SME / Make in India seller shall also be allowed to participate in the RA process. After the RA process, the award of contract(s) shall be made by the buyer keeping in view the Public Procurement Policy for Micro and Small Enterprises (MSEs) Order, 2012 and Public Procurement (Preference to Make-in-India) Order, 2017 last revised on 29.5.2019 as amended from time to time.

(w) In case any Seller / Service provider has been debarred in any particular Department / Organization, Buyers of that particular Department / Organization only shall have the right to disqualify such Sellers / Service providers at the time of technical evaluation of Bids during the period of debarment, subject to the condition that orders of such debarment has been taken with approval of Competent Authority of that Department / Organization and has been communicated to the concerned Seller / Service Provider before bid opening date.

(x) GeM is an end to end on-line procurement portal and not a tender publishing portal. GeM has detailed GTC, product / service specific STC and a rich ATC library in-built in the portal which can be used to create a comprehensive bid document. Based on the available terms and conditions, there is hardly any need to add any additional conditions to be attached with any GeM bid. However, for inclusion of some clause which is considered absolutely necessary for that particular bid for reasons to be explained in detail, a provision for inclusion of additional conditions in the bid through corrigendum is available in Request Management System. Only indispensable conditions that are not covered in and are not in conflict with GeM GTC, Product / Service STC and the standard ATC library, and which are in compliance with the Govt. orders on Public Procurement and are not restrictive and not against the core principals of transparency, fairness and efficiency enshrined in GeM, can be requested through RMS ATC request for making part of GeM bid through corrigendum. Each such request has to be made only after due approval of the Competent Authority in Buyer Organization confirming that the request has been made with the approval of the Competent Authority. Buyer organization shall be solely responsible for the impact of the requested clauses on the bidding process and its outcome. The clauses which are already covered in standard ATC library available on GeM Portal, will not be allowed through RMS.

(y) Determination of eligibility in case of products requiring BIS License: In case the bid requires availability of BIS License, bidder has to upload currently valid and operative BIS License copy (Valid on the date of bid

opening) to be considered eligible. Submitted BIS License may be in the name of Bidder / OEM or in the name of the Manufacturer to whom the OEM has outsourced manufacturing of his brand of product. The name of the Brand of the offered product should be mentioned in the BIS License. BIS certificate issued under Compulsory registration Scheme for electronic products to OEM/Brand owners for the products marketed under their brand name wherein their products are manufactured at third-party manufacturing unit is valid and is allowed for participation in the bids floated on GeM. The Manufacturer's Authorization in all such cases wherein the manufacturing is done by a third party shall be issued by the Brand owner / OEM and not by the third-party manufacturing unit mentioned in the BIS certificate.

- (z) **Bid Splitting:** In case of critical / vital / safety / security nature of the item, and / or large quantity under procurement and / or urgent delivery requirements and / or inadequate vendor capacity, Buyer may decide to have more than one source of supply. In such cases Buyer may opt for Bid Splitting while creating the bid on GeM, clearly indicating the Bid Splitting ratio in which order will be split among L-1, L-2, L-3 etc as per ratio of splitting pre-disclosed in the bid . After technical and financial evaluation, before splitting the quantity, it should be ensured by the Buyer that the L1 price is reasonable. After deciding the acceptable reasonable price, L1 would be awarded contract for at least the first / highest percentage indicated in the bid splitting ratio. For the rest of the bid quantity, the L-1 rates / lowest accepted rate will be counter offered to the next higher quoting bidder(s) for price matching. On acceptance of the counter offer, the order will be placed on next higher quoting bidder(s) for the respective percentage. In case of non- acceptance of the counter offer by the next higher quoting bidder(s), a similar offer shall be made to L3 and L4, and so on. In case counter offered rates are not accepted for ratio of splitting quantity as per bid document by any of the subsequent bidders, the left over quantity will be divided between bidders who have accepted the rates in the ratio of their originally allocated quantities subject to their confirmation and after getting consent on mutually agreed delivery schedule

for the additional quantity.

5. Contract(s):

Following documents shall be construed to be part of the contract generated through GeM:

- i. Scope of supply including price as enumerated in the Contract Document.
- ii. General Terms and Conditions (GTC).
- iii. Product / Service specific Special Terms and Conditions (STC).
- iv. Product / Track / Domain Specific STC of Particular Service including its SLA (Service Level Agreement)
- v. Bid / RA specific Additional Terms and Conditions (ATC).

The Terms and Conditions stipulated in STC & SLA will supersede those in GTC and Terms and Conditions stipulated in ATC will supersede those in GTC and STC in case of any conflicting provisions.

6. Prices:

- i. **Offer price on GeM portal:** The prices of the offered Goods or Services shall be firm and fixed at any point of time and shall be indicated in INR for each accounting unit. The Seller can choose to offer Goods or Services with uniform all inclusive unit price for deliveries at locations across India on All India basis or for specified locations selected at the time of product listing. As such, for supply of Goods contract, no additional charges such as local levies / transportation / loading unloading charges etc., shall be payable over and above the contract price. For selected freight intensive products, as notified on GeM, the Seller may quote unit price inclusive of GST with delivery charge(s) (including transportation, loading unloading and local levies) payable extra as defined in the relevant categories. In respect of items requiring installation and / or commissioning and other services (as indicated in technical details of the item), the charges for the same shall also be included in the offered price on GeM.

Once a Buyer carts a particular quantity of offered Goods / Service, during carting period as notified from time to time on GeM, rates for carted quantity, for that buyer, are frozen for the period as specified on the portal against any upward revision by seller. However, advantage of any downward revision in the offer price of carted item shall be automatically provided to the buyer.

- ii. **Offer price in e-bidding:** Bidder is required to indicate offer price in the price schedule as provided in the bidding document. Complete breakup of price as required must be indicated. However evaluation of the bid shall be on the basis of total all inclusive, landed price at consignee destination (unless otherwise specified in the ATC).
- iii. **Offer price in RA:** Bidder is required to indicate total offer price. Evaluation of the bid shall be on the basis of total all inclusive, landed price at consignee destination (unless otherwise specified in the ATC). Successful bidder shall have to provide complete breakup of the quoted price in the required price bid format before award of contract.

7. Performance Security and Performance:

- i. *There shall be no Performance security / PBG requirement for contracts:*
 - a) *Placed under Direct Purchase / L-1 Purchase Option under Para (i) and (ii) of GFR rule 149;*
 - b) *Placed through Bids / RA with estimated bid value up to Rs 5 Lakh (in case of Goods contracts); and*
 - c) *Placed through Bids / RA with estimated bid value up to Rs 5 Lakh (in case of Services contracts)*
- ii. In case of contracts placed following e-Bidding / RA, Performance Security / Performance Bank Guarantee (PBG) (in format provided on GeM) valid for 2 months beyond the date of completion of all contractual obligations including warrantee obligations, will be obtained from the successful Bidder, for ensuring due performance of the contract. GeM recommends quantum of Performance Security @ 2% of the value of contract. The Buyer also has the option to select Performance Security between 2% to 10%. While finalizing e-

Bid / RA, Buyer shall indicate the % of Performance Security required to be submitted by successful bidders. In case of any extension of contract obligation period, the seller shall be liable to suitably extend the validity of the Performance Security.

Such Performance Bank Guarantee, in prescribed format, from a scheduled commercial bank must be submitted by Seller to the Buyer within 15 days of award of contract on GeM. The payments to the seller shall become due only after receipt of Performance Bank Guarantee by the Buyer and verification of its genuineness.

If the Seller fails or neglects to observe or perform any of his obligations under the contract it shall be lawful for the Buyer to forfeit either in whole or in part, the Performance Security furnished by the Seller.

If the Seller duly performs and completes the contract in all respects the Buyer shall, refund the Performance Security to the Seller within 30 days of completion of all contractual obligations by the Seller.

8. Duties & Taxes:

- i. Offer Prices on GeM shall be on all inclusive basis i.e. including all taxes, duties, local levies / transportation / loading-unloading charges etc. In the case of Bid / RA, complete break-up of the quoted price in the required price bid format shall furnished by the Bidder, before award of contract.
- ii. Statutory variation in the rate of GST, taking place between the date of award of contract and the original / refixed delivery period, shall be to the Buyer's account. For claiming any change in price due to such Statutory variation, the seller shall have to lodge claim before the Buyer providing documentary evidence of change in rate of GST taking place after the date of award of contract and the date of supply within the original / refixed delivery period. Buyer shall issue necessary amendment in the contract to enable generation of supplementary invoice or revised invoice as the case may be.
- iii. No increase in price on account of statutory increase in the rate of GST taking place during the period of delivery period extension with liquidated Damages shall be admissible. Nevertheless the Buyer shall be entitled to the

benefit of any decrease in price on account of reduction in GST taking place during extended delivery period.

- iv. The Bill Form / On-line invoice shall be generated by the Seller which may inter-alia include the following confirmations from the Seller:
 - a. Certified that the Goods and Services Tax (GST) charged on this Bill is not more than what is payable under the provision of the relevant Act or the Rules made there under.
 - b. Certified that the goods on which GST has been charged have not been exempted under the GST Act or the rules made there under and the charges on account of GST on these goods are correct under the provisions of that Act or the Rules made there under.
 - c. Certified that the Seller is registered with above indicated GSTIN as dealer in the State where in their Billing address is located for the purpose of GST.
 - d. The on-line bill form / invoice generated on GeM is not a replacement for the GST invoice. The proper GST invoice as per requirements of GST rules shall be sent by the seller to the buyer / consignee directly along with the Goods / Services as and when deliveries are made to the consignee.
- v. Seller shall comply with all the necessary statutory compliances including but not limited to providing GST invoices or other documentation as per GST Law relating to the supply of Goods or Services, uploading the details of the invoices, payment of taxes, timely filing of valid statutory returns for the tax period in the GST portal. In case the Input Tax Credit of GST is denied or demand is recovered from Buyer on account of any act/ omission of the Seller in this regard, the Seller shall be liable in respect of all claims of tax, penalty and / or interest, loss, damages, costs, expenses and liability that may arise due to such non-compliance. Buyer shall have the right to recover such amount from any payments due to the Seller or from Performance Security, or any other legal recourse from the said Seller. If any tax is required to be paid by the Seller in pursuance of any demand from tax authorities, on account of Seller's suppression of facts, fraud or wilful misstatement of facts while

offering the products or submitting the bids, then the same shall not be passed on to Buyer through debit notes or Invoices or Supplementary Invoices and the seller shall be solely liable for payment of the same.

9. Integrity Pact:

All the Users in GeM i.e. Seller as well as Buyer agree not to indulge in any corrupt practices including without limitation any activity or action to influence the transaction on any aspect of contract and commit to take all measures necessary to prevent corruption maintaining complete transparency and fairness in all activities related to GeM. Users agree to follow and adhere with the Integrity Pact guidelines provided on GeM Portal.

10. Guarantee And Warrantee:

- i. The Goods/Services supplied under the Contract(s) shall be in accordance with the contract specifications & quality and the Goods shall be brand new and have standard Guarantee/Warrantee for one year period from the date of final acceptance by the consignee unless otherwise specified in category specifications, specific Bid/RA . Seller, at the time of listing their product on GeM portal or offering their products against any Bid / RA, may accordingly provide longer Guarantee/Warrantee period (i.e. more than 1 year) and in such case, Guarantee/Warrantee period stipulation made in category specifications / Bid / RA document, shall prevail over standard Guarantee / Warrantee period of 1 year stipulated in these General Terms and Conditions.
- ii. Notwithstanding the fact that the Buyer or its Quality Assurance Officer may have inspected and/or approved / accepted the said Goods, it is further guaranteed that if during the said guarantee / warrantee period, the Goods be discovered not to conform to the requisite description and quality and/or not giving satisfactory performance or have deteriorated, and the decision of the Buyer in that behalf shall be final and binding on the Seller and the Buyer shall be entitled to call upon the Seller to rectify and/or replace the Goods or such portion thereof as is found to be defective by the Buyer within 7 days.

Otherwise, the Seller shall pay to the Buyer such compensations that may arise by reasons of the warranty therein contained. In cases requiring Spares, the Seller guarantees that they will supply Spare Parts, if and when required on agreed basis for an agreed price for a minimum period of three years from the date of expiry of warrantee period (unless otherwise specified in STC / ATC). The agreed basis could be, including but without any limitation, an agreed discount on the published catalogue or an agreed percentage of profit on the landed cost. The aforesaid provisions made specifically for Goods, shall also be applicable for Services to the extent the same are practically possible.

11. Buyer / Consignee's Right Of Rejection (Return Policy):

- i. The Goods delivered shall bear the self certified Manufacturer's/Seller's Warranty/Guaranty. Buyer / Consignee shall have the right to inspect the supplied Goods themselves and/or through their appointed agency at consignee's own cost, at Consignee's site(s) after receipt and accept or reject on proper justification any consignment of the Goods received within a period of 10 days (unless otherwise specified in STC or ATC) of receipt of consignment of goods. The date of receipt shall be reckoned from the date of receipt of the Goods as notified in the Provisional Receipt Certificate (PRC) which will be issued online by consignee immediately after receipt of Goods.
- ii. In case of Service contract, the Buyer reserves right to reject the same in conformance with the terms and conditions of the agreed Service Level Agreement (SLA). However, such right to reject services offered by the Seller under the contract shall be exercised by the Buyer within 10 days (unless otherwise specified in STC or ATC) of the date of receipt of the Service. The date & time of start and completion of the Service, shall be indicated by the Seller while raising on-line invoice for a specified period of Service as per Service Level Agreement (SLA). The date of such invoice or the date of completion of the service, whichever is later shall be reckoned as date of receipt of the Service.
- iii. On Acceptance / Part Acceptance or Rejection of Goods / Services, Consignee will issue an on line 'Consignee's Receipt cum Acceptance Certificate' (CRAC), which will form the basis of Payments to the Seller.

iv. No payment shall be made for rejected goods or services. After intimation of the rejection / part rejection by the Buyer/ Consignee, the Seller shall be liable to remove / lift back such rejected Goods within 10 days without any extra charge/cost to the Buyer / Consignee failing which suitable ground rent / warehousing charges would be payable by the Seller to the Buyer /Consignee. If the Seller fails to remove / lift back such rejected Goods within reasonable time period, the Buyer / Consignee shall have the right to dispose off such rejected goods at the risk and cost of the seller.

12. Payment Authority and Payment Terms:

Payments shall be made to the Seller in the manner below:

i. For Goods :

In case of goods, 100% payment will be released within ten (10) days of issue of consignee receipt-cum-acceptance certificate (CRAC) and on-line submission of bills unless otherwise specified in STC / ATC.

ii. For Services:

In case of services, 100% payments on the basis of monthly (unless otherwise specified) bills will be paid within ten (10) days of issue of consignee receipt-cum-acceptance certificate (CRAC) and on-line submission of bills unless otherwise specified in STC / ATC.

13. Terms of Delivery:

All the Goods or Services in the GeM shall be offered on Free Delivery at Site basis including loading/unloading. In respect of items requiring installation, commissioning and other services in the scope of supply (as indicated in respective product category specification / STC / ATC), the cost of the same shall also be included in the offer price.

14. Delivery Period

Seller shall indicate the quantity which can be supplied over the specified time period(s). The Seller would offer these details, which would constitute the part of the awarded Contract(s) in the GeM and would make a binding Contract between

the Seller & the Buyer. Any modification thereto shall be mutually agreed and incorporated in the Contract. This Delivery Period/Time shall be deemed to be essence of the Contract and delivery must be completed not later than such date(s).

15. Extension of Delivery Period and Liquidated Damages:

Buyer may, on the request of the Seller or otherwise, extend the delivery date suitably subject to the following conditions:

- i. The original Delivery Period may be re-fixed by the Buyer without any Liquidated damages subject to Force Majeure conditions mentioned below and also on the ground/reasons of delay attributable to the Buyer / Consignee.
- ii. For other cases, provided the price trend is not lower, the Delivery Period may be suitably extended for which an amount equal to the Liquidated Damages for the extended period(s) for delay in the supply of the Goods/Services after the expiry of contract delivery period /re-fixed delivery period, shall be recovered from the Seller as mentioned hereinafter for the extended period. No increase in price on any ground after the original/re-fixed delivery date shall be admissible during such extended period(s). Nevertheless the Buyer shall be entitled to the benefit of any decrease in price on account of reduction in GST taking place during extended delivery period.
- iii. **Liquidated Damages:** If the Seller fails to deliver any or all of the Goods/Services within the original/re-fixed delivery period(s) specified in the contract, the Buyer will be entitled to deduct/recover the Liquidated Damages for the delay, unless covered under Force Majeure conditions aforesaid, @ 0.5% per week or part of the week of delayed period as pre-estimated damages not exceeding 10% of the contract value without any controversy/dispute of any sort whatsoever.

iv. Force Majeure Conditions :

If at any time during the continuance of the Contract, the performance in whole or in part by either party of any obligation under this Contract shall be prevented or delayed by the reasons of any war, hostility, acts of the public enemy, epidemics, civil commotion, sabotage, fires, floods, explosion,

quarantine restrictions, strikes, lockouts or act of God provided notice of happening of such event duly evidenced with documents is given by one party to the other within 10 days from the date of occurrence thereof, neither party shall be by reasons of such event, be entitled to terminate the Contract nor shall either party have any claim for damages against the other in respect of such non-performance or the delay in performance, and deliveries under the contract shall be resumed as soon as practicable after such event has come to an end or ceased to exist, and the decision of the Buyer as to whether the deliveries have been so resumed or not, shall be final and conclusive, Provided further that if the performance in whole or part of any obligation under this contract is prevented or delayed by reason of any such event for a period exceeding **10 days**, either party may at its option terminate the contract provided also that the Buyer shall be at liberty to take over from the Seller at a price to be fixed by Buyer, which shall be final, all unused, undamaged and accepted material, bought out components and Goods in course of manufacture in the possession of the Seller at the time of such termination or such portion thereof as the Buyer may deem fit excepting such materials, bought out components and Goods as the Seller may with the concurrence of the Buyer elect to retain.

16. Dispute Resolution Between Buyer and Seller:

AMICABLE SETTLEMENT:

In the event of any question, dispute or difference arising connection with the Contract, the Parties shall use their respective reasonable endeavour to settle any dispute amicably. If a Dispute is not resolved within 30 days after written notice of any dispute by one Party to the other, the same shall be resolved through the mechanism of a co-ordination committee to be formed by the Buyer and Seller/Service Provider and to be chaired by the Primary User of Buyer Organization/Department along with representatives from Buyer Department and Seller.

ARBITRATION:

In the event of any question, dispute or difference arising under the terms and

conditions of the contract placed through GeM, the same shall be referred to the sole arbitration by an officer nominated as Arbitrator by the Primary Buyer of the concerned Buyer Organization. It will be no objection that the arbitrator is a Government Servant and that he had to deal with the matters to which the contract relates or that in the course of his duties as a Government servant he has expressed views on all or any of the matters in dispute or difference. The award of the arbitrator shall be final and binding on the parties to the contract. The arbitration shall be governed as per Indian Arbitration and Conciliation Act 1996 as amended up to date. The place for arbitration shall be at the place from where contract has been placed by the Buyer or at the place of Primary Buyer as decided by the Primary Buyer.

In the event of the Arbitrator dying, neglecting or refusing to act or resigning or being unable to act for any reason, or his award being set aside by the court for any reason, it shall be lawful for the Primary Buyer to appoint another arbitrator in place of the outgoing arbitrator in the manner aforesaid.

In respect of all contract placed through GeM, the dispute would not be referred or entertained by Micro and Small Enterprise Facilitation Council, Consumer Forum or any other adjudication forum.

All disputes in connection with the Contract, shall be subject to the exclusive jurisdiction of the Court within the local limits of whose jurisdiction, the place from where Contract was issued is situated

GeM SPV would not be a party to any such dispute/matter.

In case any Seller / Service provider makes GeM a party / respondent in any case involving any dispute between Buyer and Seller arising out of a concluded contract or arising out of bidding process initiated / concluded by the Buyer on GeM, it would be obligatory on the part of the Buyer to represent GeM also through their Counsel / Lawyer in the proceedings before the legal authority and ensure timely filing of replies / affidavits etc provided by GeM also through their Counsel / Lawyer before the concerned legal authority during the course of litigation. A standard reply on behalf of GeM, covering following aspects shall be incorporated in all replies / affidavits filed by the Buyer in such cases:

“Government e-Marketplace is a National Public Procurement Portal; an end-to-end online Marketplace for Central and State Government Ministries / Departments, Central & State Public Sector Undertakings (CPSUs & SPSUs), Autonomous institutions and Local bodies, for procurement of common use goods & services. Prima facie, the dispute in the present case appears to be between the Buyer and Seller arising out a contract placed / bid created by the Buyer on Government e-Marketplace. As per Clause 16, Clause 17 and Clause 22 of the General Terms and Conditions of Government e-Marketplace (duly accepted by the Buyer and Seller), GeM is not to be made a party to any dispute between the Buyer and the Seller. As such Government e-Marketplace is liable to be deleted from the array of parties.

In light of the above, we request your goodself to kindly delete Government e- Marketplace from the array of parties.”

17. Laws Governing the Contract:

- i. The contract shall be governed by the laws of India for the time being in force.
- ii. Irrespective of the place of delivery, the place of performance or the place of payment under the contract, the contract shall be deemed to have been made at the registered address of the Buyer and / or Primary Buyer.
- iii. Jurisdiction of Courts: The courts of the place from where the contract has been made shall alone have jurisdiction to decide any dispute arising out of or in respect of the contract.
- iv. GeM SPV would not be a party to any such litigation.
- v. In case any Seller / Service provider makes GeM a party / respondent in any case involving any dispute between Buyer and Seller arising out of a concluded contract or arising out of bidding process initiated / concluded by the Buyer on GeM, it would be obligatory on the part of the Buyer to represent GeM also through their Counsel / Lawyer in the proceedings before the legal authority and ensure timely filing of replies / affidavits etc provided by GeM also through their Counsel / Lawyer before the concerned legal authority during

the course of litigation. A standard reply on behalf of GeM, covering following aspects shall be incorporated in all replies / affidavits filed by the Buyer in such cases:

“Government e-Marketplace is a National Public Procurement Portal; an end-to- end online Marketplace for Central and State Government Ministries / Departments, Central & State Public Sector Undertakings (CPSUs & SPSUs), Autonomous institutions and Local bodies, for procurement of common use goods & services. Prima facie, the dispute in the present case appears to be between the Buyer and Seller arising out a contract placed / bid created by the Buyer on Government e-Marketplace. As per Clause 16, Clause 17 and Clause 22 of the General Terms and Conditions of Government e-Marketplace (duly accepted by the Buyer and Seller), GeM is not to be made a party to any dispute between the Buyer and the Seller. As such Government e-Marketplace is liable to be deleted from the array of parties.

In light of the above, we request your goodself to kindly delete Government e- Marketplace from the array of parties.”

18. Limitation of Liability:

Notwithstanding anything contained in this agreement, no party will be liable for any special, incidental or consequential damages arising out of or in connection with this agreement or any breach hereof (including for loss of data or profits, or cost of cover), whether or not such party has been advised of the possibility of such damages, and whether under a theory of contract, tort (including negligence) or otherwise; except for liabilities arising out of any violation, misappropriation or infringement of a party’s intellectual property rights, or from a breach by either party of its obligation. In no event will either party’s aggregate liability arising out of or in connection with this agreement or any breach hereof (whether under a theory of contract, tort (including negligence), warranty or otherwise) exceed the Contract Price entered into the Contract between Buyer and Seller.

19. Termination for Default:

If the Seller does not perform its obligations within the Delivery Period/Date mentioned in the Contract, the same would constitute the breach of the Contract and the Buyer shall have the right to Cancel or withdraw the Contract for the unsupplied portion after the expiry of the original or re-fixed delivery date or period stipulated in the Contract. Such cancellation of contract on account of non-performance by the Seller would entitle the Buyer to forfeit the performance security besides other actions such as downgrading the Seller's rating or debarment from the GeM for specified period as decided by GeM on merits.

20. Closure of Transaction:

After satisfactory completion of all the obligations under the Contract and release of payments for the goods / services, the transaction shall be treated as closed.

21. Grounds for Administrative Action

- (i) Administrative actions may be taken by GeM against the Buyer or the Seller either suo-moto on the basis of the platform mechanisms identified through analytics or on the basis of a complaint or report made to GeM by any stakeholders or any third party information or upon Court order, inter –alia, for non-adherence to the GeM Website Policies including Terms and Conditions and the Incident Management Policy published on the GeM Website.
- (ii) The Seller would be liable for administrative actions such as suspension / debarment / removal from GeM, if they fail to abide by any of the Website Policies including the terms & conditions stipulated in this document and/or on anyone or more of the following grounds:
 - (a) Listing the products/services not in the relevant categories and/or listing the same with vague/conflicting product specifications/details and irrelevant product photographs.
 - (b) Offering Goods / Services without having proper authorization
 - (c) Supplies goods of inferior/ substandard quality
 - (d) Supplies or offers to supply refurbished or counterfeit or fake products

- (e) Withdraws or modify or impairs or derogates from the bid in any respect within the period of validity of its bid;
 - (f) Seller furnishes inaccurate, false, misleading or forged or fails to furnish any information / documents, within the prescribed time limits, to GeM or to a Buyer, including during e-Bidding/ RA process;
 - (g) Fails to furnish requisite performance security / PBG within stipulated time required as per e-bid / RA conditions;
 - (h) Fails to update GeM about any change in information furnished within the prescribed time limits;
 - (i) Executes services without conforming to requirement given in Service Level Agreement (SLA);
 - (j) Fails to execute an order/ contract or fail to execute it satisfactorily
 - (k) Is declared bankrupt or insolvent;
 - (l) Fails to produce the requisite documents/ information during the course of inspection / assessment at any stage;
 - (m) Performs any activity which is listed as prohibited activities on GeM.
 - (n) On any other ground for which, in the opinion of GeM, the retention of the seller or any of its offered product in GeM is not in Public Interest.
 - (o) The grounds mentioned above are illustrative only. Users are also advised to read the list of prohibited activities published on the website.
- (iii) Notwithstanding anything contained in the GTC, GeM reserves the right to cancel or annul the registration of any Seller or remove any of the Good/Services listed by a Seller on the GeM Website to comply with any provision of the Applicable Laws and / or Court Orders.
- (iv) GeM may take an administrative action in terms of the GeM Website Policies against a Buyer which may include reporting of any breach or misconduct to the Buyer Primary User and/or to the competent authority and GeM reserves the right to review the rating of such Buyer, and / or block Buyer's account for such time as considered appropriate by GeM.
- (v) The Seller and the Buyer understands that the grounds for

administrative action as provided under the Contract are only indicative and additional grounds may be provided under the GeM Website Policies including the Incident Management policy. The Seller / Buyer warrants to abide by all additional grounds as may be specified by GeM in the GeM Website Policies from time to time.

22. Role of Government E- Marketplace - Gem SPV

Government e-Marketplace – GeM SPV is the owner of the GeM portal which monitors and supervises all the business transactions on the portal. The role and responsibilities of the company are as under:

- a. To develop, operate and maintain technology driven e-marketplace, through a Managed Service Provider (MSP), to be used by government agencies for procurement of various goods and services in a transparent and efficient manner.
- b. Overall supervision and monitoring of GeM portal operations, policy management, finalization and implementation of various business processes and work flows in adherence with the applicable law and executive orders issued from time to time . To provide tools for on-line Bidding, on-line Reverse Auction and Business Analytics Tools on GeM.
- c. To work continuously for improvements in the Business Processes and Work Flows for various activities / functions on GeM based on feedback from various stakeholders to enhance transparency, efficiency, competitiveness, equality, economy in procurement of goods and services by government agencies.
- d. To finalize General Terms and Conditions for sale and purchase of Goods and Services on GeM, Product / Service Specific Special Terms and Conditions, Special Terms and Conditions for Bunching of Goods / Services, Bid Specific Special Conditions, Project Specific Special Conditions etc.
- e. To finalize, upload and approve Technical Specification Frameworks for various item / service categories on GeM and to monitor conformity of offered products to the larger framework so finalized and uploaded.
- f. To decide addition / deletion of any of the offered product(s)/Product

category (ies) and their framework of technical parameters on GeM.

- g. To work and co-ordinate with different Organizations/Departments / Agencies for integration of their Databases with the GeM portal on real time basis for the purpose of verification/authentication of data entries made by stakeholders.
- h. To offer and manage Demand Aggregation services for identified categories across buyers with assured reasonability of price, recommending for placement of orders by individual buyers
- i. To co-ordinate with MSP for conducting workshops for the various Stakeholders in capacity building and in change management associated with the implementation of technology enabled procurement process.
- j. To monitor MSP that the Buyers, Sellers and Service Providers are being assisted properly by them to onboard their goods and services on the GeM platform.
- k. To identify and offer services of 3rd parties for Vendor Assessment relating to technical, financial capacity, past experience of sellers including manufacturing
/ testing facilities / quality control arrangement(s) of manufacturing premises and/or any of the premises related to manufacturing process of products / services offered by the seller / service provider on GeM.
- l. To identify and offer services of 3rd parties for testing and certifying the quality of the product offered/ supplied, through documents, test reports/ certificates, testing at any independent lab or through inspection/testing by its authorized representative/s at firm's premises or at user's premises, that buyer choose to use.
- m. Overall monitoring and management of Call Centre/Help desk operations being provided by the MSP.
- n. Removal / debarring the Sellers/Buyers and Goods / services in GeM.
- o. Management of complaints and their redressal mechanism in GeM (not disputes related to concluded contracts).

- p. To identify, integrate and manage MoUs with verifying, certifying and validating entities across government(s) and also professional agencies to reinforce the online paperless, contactless and cashless system on GeM.
- q. To issue Notices, Circulars, News, Flashes, Updates etc in GeM
- r. Reporting and MIS mechanism in GeM
- s. Any other related activities in the GeM
- t. In exceptional circumstances, for ensuring propriety of procurement processes or to obviate possible misuse of GeM functionalities, GeM SPV as GeM Admin may keep any Bidding / RA process on hold for some time as considered appropriate.
- u. To take approved User Charges from Buyers and Sellers for the various transactions on the GeM portal as decided and notified on the GeM portal.

23. Miscellaneous Provisions

- a. **Assignment:** Users understand and agree that the GTC, STC and ATC provisions, rights and obligations granted by GeM are non- transferrable or assignable by the User to any third party, without the prior written consent of GeM. If same is permitted by GeM, all the conditions, rights and obligations of the GTC or any on-going STC/ATC shall also be binding upon such third party assignee besides the User.
- b. **Indemnification:** The Seller shall at all time indemnify Buyer against all suits and claims which may be made in respect of the goods/services for infringement of any right protected by patent, registration of designs or trade mark. Provided always that in the event of any claim and suit in respect of alleged breach of patent, registered designs or trade-mark being made against the Buyer, the Buyer shall notify the Seller/ Service Provider of the same who shall at its own expense either settle any such dispute or conduct and litigation that may arise there from.

Buyers and Sellers agree to indemnify, defend and hold harmless GeM, its officials, Managed Service Provider (herein after individually and collectively referred to as "indemnified parties") from and against any and all losses,

liabilities, claims, suits, proceedings, penalties, interests, damages, demands, costs and expenses (including legal and other statutory fees and disbursements in connection therewith and interest chargeable thereon) asserted against or incurred by the indemnified parties that arise out of, result from, or in connection with

- i. Breach of the contract(s); or
- ii. Any claims made by any third party due to, or arising out of, or in connection with, use of the Website; or
- iii. Any claim made by any third party regarding content/ information or materials provided by Seller cause any damage to a third party; or arising out of, or in connection with, use of the Website.
- iv. Violation of any intellectual property rights or any other rights.

Once GeM notifies the Buyer/ Seller of such claims, they shall defend and indemnify GeM for the same. Further, in no case they shall compromise or settle any claim or admit any liability on the part of GeM without the express or prior written consent of GeM which can be withheld or denied or modified by GeM in its sole discretion or as per the Applicable Laws.

- c. **Severability:** If due to any change in Applicable laws, certain part of the GTC or any applicable STC or any provisions of the GeM policies or portions thereof, becomes unenforceable, the remaining provisions shall continue in full force and effect so as to give effect to the intent of the parties.
- d. **Website Terms and Policies Update:** Buyers and Sellers are advised to check the website terms and conditions as well as policies such as Privacy Policy and the Website Disclaimer at all times, as GeM may update the Website and such terms from time to time.
- e. **List of Prohibitive Activities (Suggestive And Non-Exhaustive):**
LIST OF PROHIBITIVE ACTIVITIES: The following is an indicative list of prohibitive activities which the Buyers and the Sellers registered on GeM platform shall not perform on the GeM platform. A breach of any of the prohibited activities shall give the right to GeM under the Applicable Laws or in terms of these GTC or the GeM Website Policies to take administrative

action which may include partial or permanent disabling of account on GeM Website, debarment etc. Additionally, GeM may remove any non-compliant information and reserves the right to preserve and share with the appropriate authority such information and associated records for investigation purposes. The Buyer and the Seller understand that this list is only indicative and additional activities may be prohibited under the GeM Website Policies. The Buyers and the Sellers shall undertake to provide their full support that may be required by GeM for removal and disabling of the non compliant information. The prohibited activities include:

- (i) Indulging in cyber crime or other criminal activities which can become a threat to GeM, GeM Website, to the Government of India or to any State Government or Government Agency.
- (ii) Advertising, exhibiting, representing, publishing, pronouncing, listing, delivering, offering to sell or selling any kind of Goods/Services which can cause any kind of infringement or disparagement of intellectual property rights.
- (iii) Selling refurbished, counterfeit and/or fake Goods / Services under a brand or misusing others brand name.
- (iv) Offering to sell or selling above the MRP any Goods or misrepresenting the MRP.
- (v) Delivering some other Goods or Services instead of the Goods or Services Contracted for or delivering empty parcels or used Goods in breach of the terms of the Contract.
- (vi) Offering to sell or selling freebies which are 'Not for sale' Goods.
- (vii) Listing of the Goods on GeM Website without authorization to sell Goods manufactured by the OEM in open market or without proper authorisation, if any required, for providing the Service.
- (viii) Listing of the Goods or Services is done on GeM Website without guarantee/warranty or without a genuine guarantee/warranty.
- (ix) Listing of the Goods or Services in irrelevant or inappropriate categories or

with vague or conflicting specifications or description (including descriptive or pictorial description).

- (x) The Buyer /Seller registering on GeM and/or offering or buying the Goods and/or Services and/or participating in e-bidding/reverse auction on GeM, without the requisite authorization to enter into contract on behalf of the concerned legal entity. Failing which such individual(s) shall be individually liable for its actions and also for any liability arising out of such actions.
- (xi) If any Seller has been debarred from GeM then such Seller or their authorized sellers shall also not be permitted to register and offer/sell their products on GeM and / or participate in Bids / RA on GeM.
- (xii) Using GeM prices for making procurement outside GeM Portal.
- (xiii) Splitting of demands by creating multiple Bids/RAs of same goods / services or making repeated procurements of same goods/services through Direct Purchase / L-1 buying as per rule 149(i) and 9(ii) of GFR- 2017.
- (xiv) Uploading goods / services containing information that —
 - (a) belongs to another person and to which the user does not have any right to;
 - (b) is grossly harmful, harassing, blasphemous, defamatory, obscene, pornographic, paedophilic, libellous, invasive of another's privacy, hateful, or racially, ethnically objectionable, disparaging, relating or encouraging money laundering or gambling, or otherwise unlawful in any manner whatever;
 - (c) harm minors in any way;
 - (d) infringes any patent, trademark, copyright or other proprietary rights;
 - (e) violates any law for the time being in force;
 - (f) deceives or misleads the addressee about the origin of such messages or communicates any information which is grossly offensive

or menacing in nature;

(g) impersonate another person;

(h) contains software viruses or any other computer code, files or programs designed to interrupt, destroy or limit the functionality of any computer resource;

(xv) threatens the unity, integrity, defence, security or sovereignty of India, friendly relations with foreign states, or public order or causes incitement to the commission of any cognizable offence or prevents investigation of any offence or is insulting any other nation.

(xvi) Achieving or trying to achieve illegal access to features on GeM Website not specifically authorised or exceeding the scope of authorized access to or other features of the GeM Website;

(xvii) Obstructing or causing GeM to lose (in whole or in part) the services provided by any internet service provider ("ISPs") or carrying out any cyber security incident;

(xviii) Sending unsolicited emails, bulk messaging, auto messaging, junk email, spam and like.

24. Incident management Policy on GeM: GeM is a trust based system and self-declaration is the key, along with a strong automated process to penalize any deviant behaviour on part of Sellers / Buyers. For this purpose, deviations from the terms and conditions of procurement on GeM, including general terms and conditions, special and additional terms and conditions and any other relevant Government rules and guidelines, are termed as “deviation”. A deviation can occur while listing the products on GeM, at pre-contract stage, during bidding or at post contract stage on GeM. The mechanism for reporting and initiating action on such deviation has been detailed in the Incident Management Policy available on GeM portal under Resources. All stake holders of GeM shall be bound by the actions as detailed in the Incident Management Policy.

All administrative actions under this Incident management Policy, taken by GeM

against any of the stakeholders shall not cause any limitation on the legal and/or contractual remedies including any financial recoveries, available to Buyers/Sellers under the Terms and Conditions of contract and/or GeM policies. In case the Buyer / Seller choose to pursue any of these remedies, GeM shall not be made party to such proceedings / remedial actions taken by Buyer/Seller under the contractual provisions.

25. Use of Aadhaar Number in GeM: Purpose of the Aadhaar authentication in GeM is to identify the user using eKYC. GeM has provisioned the option for Sellers and Buyers to provide virtual Aadhaar ID instead Aadhaar number. GeM receives First Name, Last Name, Mobile Number, Email ID, DOB and Gender details. It is used to link the mobile number with the user who is registering on GeM; on which subsequently OTP is sent for achieving the property of non-repudiation in different artefacts / documents generated on GeM. GeM has provisioned an alternative Identity Information option through PAN based verification to Sellers.

26. Compliance of Restrictions under Rule 144 (xi) of GFR 2017: Restrictions on procurement from a bidder of a country which shares a land border with India

- I. Any bidder from a country which shares a land border with India will be eligible to bid in this tender only if the bidder is registered with the Competent Authority.
- II. "Bidder" (Seller / Service Provider) means any person or firm or company, including any member of a consortium or joint venture (that is an association of several persons, or firms or companies), every artificial juridical person not falling in any of the descriptions of bidders stated hereinbefore, including any agency branch or office controlled by such person, participating in a procurement process.
- III. "Bidder from a country which shares a land border with India" for the purpose of this Order means: -
 - a. An entity incorporated, established, or registered in such a country; or
 - b. A subsidiary of an entity incorporated, established, or registered in such a country; or
 - c. An entity substantially controlled through entities incorporated,

established, or registered in such a country; or

- d. An entity whose beneficial owner is situated in such a country; or
- e. An Indian (or other) agent of such an entity; or
- f. A natural person who is a citizen of such a country; or
- g. A consortium or joint venture where any member of the consortium or joint venture falls under any of the above

IV. The beneficial owner for the purpose of (iii) above will be as under:

1. In case of a company or Limited Liability Partnership, the beneficial owner is the natural person(s), who, whether acting alone or together, or through one or more juridical person, has a controlling ownership interest or who exercises control through other means. Explanation—
 - a. "Controlling ownership interest" means ownership of or entitlement to more than twenty-five per cent. of shares or capital or profits of the company;
 - b. "Control" shall include the right to appoint majority of the directors or to control the management or policy decisions including by virtue of their shareholding or management rights or shareholders agreements or voting agreements;
2. In case of a partnership firm, the beneficial owner is the natural person(s) who, whether acting alone or together, or through one or more juridical person, has ownership of entitlement to more than fifteen percent of capital or profits of the partnership;
3. In case of an unincorporated association or body of individuals, the beneficial owner is the natural person(s), who, whether acting alone or together, or through one or more juridical person, has ownership of
or
entitlement to more than fifteen percent of the property or capital or profits of such association or body of individuals;
4. Where no natural person is identified under (1) or (2) or (3) above, the beneficial owner is the relevant natural person who holds the position of

senior managing official;

5. In case of a trust, the identification of beneficial owner(s) shall include identification of the author of the trust, the trustee, the beneficiaries with fifteen percent or more interest in the trust and any other natural person exercising ultimate effective control over the trust through a chain of control or ownership.

V. An Agent is a person employed to do any act for another, or to represent another in dealings with third person.

VI. The successful bidder shall not be allowed to sub-contract works to any contractor from a country which shares a land border with India unless such contractor is registered with the Competent Authority.

Any false declaration and non-compliance of the above would be a ground for immediate termination of the contract and further legal action in accordance with the laws.

II. Additional Terms and Conditions on GeM:

1. ISO 9001: The bidder must have ISO 9001 certification.
2. Bidder's offer is liable to be rejected if they don't upload any of the certificates / documents sought in the Bid document, ATC and Corrigendum if any.
3. OPTION CLAUSE: The Purchaser reserves the right to increase or decrease the quantity to be ordered up to 25 percent at the time of placement of contract. The purchaser also reserves the right to increase the ordered quantity by up to 25% of the contracted quantity during the currency of the contract at the contracted rates. Bidders are bound to accept the orders accordingly.
4.
 1. The Seller shall not assign the Contract in whole or part without obtaining the prior written consent of buyer.
 2. The Seller shall not sub-contract the Contract in whole or part to any entity without obtaining the prior written consent of buyer.
 3. The Seller shall, notwithstanding the consent and assignment/sub-contract, remain jointly and severally liable and responsible to buyer together with the assignee/sub-contractor, for and in respect of the due performance of the Contract and the Sellers obligations there under

5. After award of contract – Successful Bidder shall have to get advance sample approved from buyer before bulk manufacturing / starting bulk supplies. Successful Bidder shall submit 1 samples for Buyer's approval, within 15 days of award of contract. Buyer shall, as per contract specifications framework, either approve the advance sample or will provide complete list of modification required in the sample within 5 days of receipt of advance sample. Seller shall be required to ensure supply as per approved sample with modifications as communicated by Buyer. If there is delay from buyer side in approval of advance sample – the delivery period shall be refixed without LD for the period of delay in sample approval. In case, the sample is found to have major deviations / not conforming to the Contract specifications, the buyer at its discretion may call for fresh samples for approval before allowing bulk supplies or may terminate the contract after notifying the deviations to the seller. Unless otherwise provided in the contract, all samples required for test shall be supplied by the contractor free of cost. Where under the contract, the contractor is required to submit an advance sample, any expenses incurred by the contractor on or in connection with the production of stores in bulk, before the sample has been approved unconditionally shall be borne by the Seller and he shall not claim any compensation in the event of such sample being found unacceptable by the Buyer / Consignee.

III. Additional Terms and Conditions of Buyer:

1. Scope of Work:

- a. The Scope of Work includes supply of Mobile Dispensing Units to the Districts, registration of each vehicle in the name of user for which list will be provided after contract is awarded, comprehensive vehicle insurance for one year for each vehicle. The offered price will include cost of vehicle with freight charges upto consignees, registration fee of vehicle, insurance charges for one year comprehensive insurance, permit charges and all the taxes payable to supply the vehicles till the consignee (District Head Quarters).
- b. The Bidder should get pre-requisite permissions/approvals, if any, for the Mobile Dispensing Unit in accordance with Central Government Acts/laws and Andhra Pradesh Government Acts/laws.

- c. The Bidders are required to supply the Mobile Dispensing Units to the Districts of Andhra Pradesh State as per the quantity mentioned against each district. However, the quantity allocated against each district may vary.
- d. The Bidder shall provide the following Branding on the Mobile Dispensing Unit:
 - i. Cabin and Cargo Body Painting - Colour and Design as given by APSCSCL.
 - ii. Stickers area - 140 sq. ft. (One forty square feet) to 150 sq. ft. (One fifty square feet) of Stickers on the Cabin and Cargo body. Stickers Material shall be Star Vinyl with Lamination. Design as given by APSCSCL.

2. Eligibility/Prequalification Conditions:

- a. The Bidder shall be an Original Equipment Manufacturer of 4-Wheeler Mini Trucks.
- b. The Bidder shall take the responsibility of servicing for the supplied Mobile Dispensing Units periodically as per free servicing and warranty conditions.
- c. The Bidder should have minimum three years of experience in manufacturing and supplying of 4-Wheeler Mini Trucks.
- d. The Bidder should be in operation for at least last three years (FY 2017-18, FY 2018-19 and FY 2019-20) as on the date of submission of tender and average turnover of such bidder during these years should not be less than Rs. 1000 Crore per annum.
- e. The Bidder should not be blacklisted by any Government / Government undertakings.
- f. The Bidder should have the capacity and is agreeing to supply the entire requirement of Mobile Dispensing Units for the State as per the specifications given. The Bidder shall have required production, process and allied facilities with all the permission from the competent authorities.

3. Documents to be Submitted:

- a. Deed of Partnership, Copy of the Registration of the Firm with Registrar of Firms; & Memorandum & Articles of Association.
- b. Copy of Factory License

- c. Turnover Certificate from Chartered Accountant as per the format provided
- d. Self-Attested Photocopy of audited Financial Statements specifically including Balance Sheet, Profit & Loss A/c and Cash Flow Statement for FY 2016-17, FY 2017-18, FY 2018-19 and provisional for FY 2019-20.
- e. Income Tax Returns (FY 2017-18 & FY 2018-19) attested by the Chartered Accountant
- f. Internal Auditor certificate stating that the Bidder has the capacity to supply the entire requirement of Mobile Dispensing Units for the State.
- g. Affidavit on non-judicial stamp paper worth Rs. 100/- that the Bidder is not blacklisted by any Government undertakings in the format given. Affidavit duly signed by the authorized notary signatory.
- h. In case of partnership firm or Co-operative or Corporate, the Bidder should furnish a copy of the partnership deed or byelaw or Memorandum of Associations and Articles of Association as the case may be. In case of partnership firms, the share holding pattern should be duly certified by the Chartered Accountant along with details of name, age, education and experience of the partners.

4. Schedule of e-Tender:

- a. The Bidder shall take adequate care and is solely responsible to obtain details of the schedule of eTender through the GeM portal only.
- b. Corporation will not have responsibility on information obtained from other sources.
- c. The offered price will include cost of vehicle with freight charges upto consignees, registration fee of vehicle, insurance charges for one year comprehensive insurance, permit charges and all the taxes payable to supply the vehicles till the consignee (District Head Quarters).
- d. Any increase or decrease of taxes, duties, levies and other such payments shall be borne by the Bidder and the Corporation will not consider any request of enhancement in this regard.
- e. Failure to accept the contract by the successful Bidder shall result in the forfeiture of the EMD and blacklisting from further participation in the eTenders for a period of three years. The decision of the VC & Managing Director, APSCSCL in this regard will be final.

- f. In case of any clear indication of cartelization, the Corporation shall reject the tender(s), and forfeit the EMD.
- g. If the information given by the Bidder in the tender document and its Annexure/Appendices is found to be false/incorrect at any stage, the Corporation shall have the right to disqualify/summarily terminate the contract, without prejudice to any other rights that the Corporation may have under the Contract and law and may attract criminal proceedings.
- h. The Corporation reserves the right to claim from the Bidder any amount of tax, interest, penalty and litigation cost, if any, that may be incurred in future due to GST reporting/compliance mistake(s) on the part of the service provider.

5. Earnest Money Deposit:

- a. Each Bidder needs to deposit EMD prescribed in the tender along with technical bid. The EMD shall be transferred through Net Banking/NEFT/Direct Debit Facility through Debit or Credit Card/ RTGS through system generated challan. The details shall be submitted along with technical bid.

Bank Name	Bank Account Name	Account Number	IFSC Code	Branch Name
SBI	VC & MD APSCSCL	00000037270582042	SBIN0016857	MG ROAD, VIJAYAWADA

- b. The Bidder shall be permitted to bid on the express condition that in case he/she modifies his offer, or terms & conditions thereof, after submitting his tender, for any reason whatsoever during the tender process, the Earnest Money Deposited by the Bidder shall stand forfeited, without prejudice to any other rights and remedies of the Corporation under the contract and law, and the Bidder will be liable for any loss suffered by the Corporation on account of its withdrawal/modification etc., besides forfeiture of EMD. The Bidder will also be debarred from participating in any other Tender with the Corporation for a period of three years.
- c. The EMD of the successful Bidder will be retained by the Corporation.

6. Security Deposit:

- a. The successful Bidder upon receipt of communication regarding acceptance of bid shall arrange for e-Performance Bank Guarantee (ePBG) for 3% of the value of the contract within 5 (five) working days. The ePBG will be valid for 74 months.
- b. The Security Deposit will comprise of the EMD and ePBG.
- c. In the event of the Bidder's failure to pay the Security Deposit, after the communication of acceptance of the tender by the Corporation within the due date, his/her contract shall be summarily terminated besides forfeiture of the Earnest Money Deposit and the Corporation shall proceed for appointment of another Supplier.
- d. Any losses or damages arising out of and incurred by the Corporation by such conduct of the Bidder will be recovered from them, without prejudice to any other rights and remedies of the Corporation under the Contract and Law. The Bidder will also be debarred from participating in any future tenders of the Corporation for a period of three years.
- e. The EMD and ePBG furnished by the qualified Bidder will be returned on request upon completion of 6 years of Comprehensive warranty period, subject to satisfactory performance and execution of contract as per Terms and Conditions of the tender.
- f. No interest shall be given on the Security Deposit to the qualified Bidder.

7. Order for Supplies:

- a. Default in supplies either wholly or partly on account of quality or quantity or delay in supply will result in forfeiture of Security Deposit.
- b. Forfeiture of Security Deposit and criminal action shall be initiated if found at any time of contract period that the successful Bidder has colluded or partnered with any blacklisted firm.
- c. At any stage of supplies under the scheme; if it is noticed that the supplies are not in conformity with the specifications prescribed, such materials are liable to be rejected and qualified Bidder will be called upon to make good the same. In the event of Supplier failing to make good the rejected stocks, the Security Deposit furnished by the Supplier shall be forfeited.

8. Quality Assurance & Rejection:

- a. Corporation may, if need be, undertake pre dispatch inspection of stock by technical staff or appoint any other agency (Quality Certification) for that purpose at the Supplier's premises.
- b. The Post-dispatch inspection will be conducted at District-level by a committee headed by the Joint Collector of that District through a District Inspection Committee.
- c. The District Inspection Committee will inspect all the delivered Mobile Dispensing Units. The Supplier shall cooperate for the testing/inspection and shall bear any cost involved during the inspection procedure.
- d. The results of the District Inspection Committee will be final and binding on the Supplier. The stocks which does not confirm to the specifications, as decided by the District Inspection Committee shall be made good or replaced within 30 days.
- e. In case of Mobile Dispensing Units not confirming to the specifications mentioned in this document or other quality issues reported by the District Inspection Committee, the Mobile Dispensing Unit will be summarily rejected.
- f. It is the responsibility of the Supplier to get the verification done by the District Inspection Committee at the delivery locations.
- g. The District Inspection Committee may involve Sub-Committees or other qualified agencies for inspection. The Supplier should cooperate with such sub-committees or appointed agencies if any.

9. Terms and Conditions of Delivery:

- a. The Supplier shall deliver the Mobile Dispensing Units to the respective District Head Quarters and shall arrange for necessary space for parking of the Mobile Dispensing Units until the Corporation hands-over the Mobile Dispensing Units to the end user.
- b. The Mobile Dispensing Units shall be under the custody of the Supplier until the Corporation hands-over the Mobile Dispensing Units to the end user.
- c. Supplier shall furnish a daily report for the stocks delivered to the designated locations to the District Officer and the Head Office through email.

- d. The Supplier should take adequate precautions to prevent damage of Mobile Dispensing Units during storage and transportation. He should also insure the stock during transit at his cost.
- e. The Supplier will be provided login id and password and the Supplier shall enter the details of dispatches in the Supplier Module of APSCSCL.
- f. The Supplier shall comply with the directions for delivery issued from time to time by the VC & MD of the Corporation while discharging the duties under this agreement.

10. Terms of Payment:

- a. After satisfactory supply of all the ordered items by the Supplier within the stipulated time, payment will be released to the Supplier after submission of bills with relevant documents.
- b. The payment is processed based on the accepted quantity at the designated location, approval report from District Inspection Committee and is subjected to any standard deductions as specified in the Purchase Order or any penalties as mentioned in this document.
- c. After generation of online invoice, the payment will be made upon submitting the following additional documents for the entire quantity supplied as per the technical specifications indicated in the tender document duly deducting penalty amount, if any:
 - i. Quality Inspection reports from the District Inspection Committee
 - ii. Certificate of Receipt/Acknowledgement of MDUs after approval of the District Inspection Committee
 - iii. Any other relevant document/acknowledgment issued by the District Authorities
- d. The payment shall be directly released to the respective Bank Account of the Supplier.
- e. 94% of payment will be released on receipt of necessary documents mentioned above. The remaining 6% will be released over a period of 6 years (1% each year) on providing satisfactory services under the Comprehensive Warranty.
- f. No interest will be paid on outstanding bills at any time

- g. The Supplier is prohibited from claiming any higher rates towards supply of Mobile Dispensing Units other than those prescribed under this agreement due to escalation in prices of raw materials, labour cost or for any other reasons during the contract period.
- h. The VC & MD, APSCSCL also reserves the right to recover any dues from the Supplier which is found on a later date during the Audit/excess payment after final settlement is made to them. The Supplier is liable to pay such dues to the Corporation immediately on demand without any dispute / protest.

11. Other Terms & Conditions:

- a. In case of any failure in functioning of the Mobile Dispensing Units 6 month from the date of supply, the Supplier shall replace the whole unit within 30 days at their own cost to the concerned location. In case of any failure in functioning of the Mobile Dispensing Units after 6 months of supply, the Supplier shall address the issue within 48 hours and resolve within 5 (five) days.
- b. The Supplier shall have authorized service centers across the State and at least 1 authorized service centre per Revenue Division across the State. The details of the authorized service centers revenue division-wise should be provided as per format provided in the tender document.
- c. The Supplier shall provide On-Road assistance for all the Mobile Dispensing Units supplied. On-Road assistance should address and resolve any vehicle breakdown issues within 48 hours. A penalty of Rs. 500 per day will be levied in case of any delay in resolving of issues.
- d. All spare parts mentioned under Comprehensive Warranty shall be replaced whenever necessary by the Supplier free of cost until the end of 6-year Comprehensive warranty period.

12. Taxation:

Tax deducted at source (TDS), if applicable, shall be done before making payment to the Supplier as per existing laws in force and the laws time to time amended by the Central/State Governments.

13. Execution of Agreement:

The successful Bidder shall execute an agreement for the supply of Mobile Dispensing Units as per the terms and conditions mentioned in the tender on a stamp paper of value Rs 100 /- within (7) seven working days from the date of acceptance of bid. In the event of failure to execute the agreement within the time prescribed, the Security Deposit amount remitted by the Bidder shall be forfeited. Further the APSCSCL reserves the right to collect the consequential loss, if any sustained from such bidders on account of transport/purchase made through re-tender or in other manners and the bidders are bound to pay the same on demand.

14. Period of Agreement:

- a. The agreement will ordinarily be in force for a period of six years from the date of completion of supply of Mobile Dispensing Units at the designated locations as per terms and conditions of the tender.
- b. The Supplier shall complete the supply of Mobile Dispensing Units as per time frame fixed in the work order.
- c. As per the tender, the Supplier shall provide 6 years Comprehensive warranty to the Mobile Dispensing Units.

15. Cancellation of Agreement:

- a. The Supplier, if breaches any condition or clause of the agreement the Corporation is entitled to cancel the agreement and also entitled to demand and recover the loss incurred to it due to such cancellation/termination of the agreement.
- b. If the Government scheme is closed or partly revised or modified, due to fortuitous decision of State/Central Government or any amendment and the proceedings of purchase is stopped or revised or modified by the Corporation then the agreement will automatically come to an end or partly continues for which Supplier is not entitled to demand/receive any type of loss amount or cannot initiate any legal proceedings against APSCSCL.
- c. The Supplier shall notify to the Corporation the death/resignation of any of their partners/directors immediately on the occurrence of such an event. On receipt of such notice, the Corporation shall have the right to terminate the Contract if necessary.

- d. The Corporation may, without prejudice to any other remedy for breach of contract, by written notice of default sent to the Supplier reject the offer in whole or in part. Breach of contract shall include, but shall not be limited to the followings;
 - i. The Supplier unable to supply the offered quantity of the Units within prescribed time limit mentioned or
 - ii. If the Supplier fails to promptly correct the defect in the supplied goods in the time limit given or
 - iii. If the Supplier fails to perform any other obligation(s) under the Contract or
 - iv. The Corporation or the Supplier goes bankrupt or goes into liquidation other than for a reconstruction or amalgamation
 - v. Notwithstanding the above, the Corporation may terminate/reject the offer for violation of any law, for any reason of quality of supply; or for any irregularity committed by the bidder or any other like reasons.
- e. If the Contract is terminated, the Supplier shall stop supply immediately.
- f. In the event of termination of contract on account of breach of any terms and conditions of the contract by the Supplier the entire Security Deposit given by the Supplier will stand forfeited.
- g. Foreclosure - The Corporation reserves the right to foreclose the contract without assigning any reason. In such case the Supplier will not be entitled to any compensation for non-supply or loss of profit or any incidental costs of any kind. Payment shall be made only for supply made and accepted up to the date of effect of this procedure.

16. Penalty on Default/Extension Time:

- a. In the event of failure to supply the ordered quantity, by the successful Bidder within the stipulated time, the VC & MD, APSCSCL reserve the right to cancel the orders for the unsupplied quantity.
- b. The Corporation reserves the right to charge penalty as decided or withhold payment for any unsatisfactory stocks supplied by the Supplier without prejudices to other rights and the decision of the VC & MD, APSCSCL is final and binding on the Supplier. The Supplier is liable to reimburse/compensate the Corporation or

- to third party for any loss, damage, injury, etc., caused or arising out of the negligence in supply of low or inferior quality of stocks or any breach of contract.
- c. Notwithstanding anything contained in the terms and conditions of this tender the VC & MD, APSCSCL is the ultimate authority in deciding the recovery of penalty from the Supplier taking into account the stock position and future requirement of supply.
 - d. In the event of failure by the Supplier at any stage of tender process, the EMD and Security Deposit or Bills of supplied quantity will be forfeited, and along with blacklisting of the Supplier/Bidder.
 - e. If the Contract is cancelled because of any breach by the Supplier, the Corporation has every right to forfeit the Security Deposit. If Security Deposit is not sufficient, the balance amount shall be recovered from the Supplier as per Legal provisions.

17. Liability of Personnel:

All persons employed by the Supplier/Contractor shall be engaged by him as own employees in all respects, and all rights and liabilities under the Indian Factories Act, or the Workmen's Compensation Act, or Employees Provident Fund Act, and other applicable enactments, in respect of all such personnel shall exclusively be that of the Supplier/Contractor. The Supplier/Contractor shall be bound to indemnify the Corporation against all the claims whatsoever in respect of its personnel under Workmen's Compensation Act, 1923, or any statutory modification thereof or otherwise for or in respect of any damage or compensation payable in consequence of any accident or injury sustained by any workmen or other person whether in employment of the Supplier/Contractor or not.

Supplier/Contractor shall also comply with all Rules and Regulations / Enactments made by the state Govt. / Central Govt. from time to time pertaining to the contract including all Labour Laws etc.,

18. Set Off:

In the event of the Corporation having claim or claims ascertain or otherwise against the agent under any of the conditions of this contract or arising from or out of this contract or under the conditions of any other contract, the VC & MD, APSCSCL shall be entitled to retain to extent of such claim or claims, any money which may be due returned by the

Corporation to the agent under this or any other contract and shall entitled to appropriate such money or towards satisfaction of such claim or claims.

19. Notice:

Any notice, request, demand, consent, approval or other communication required or permitted under this agreement shall be in writing and shall be deemed to have been given (i) upon actual delivery, if delivery is in person, (ii) upon receipt if the delivery is by e-mail, or (iii) on the third business day following delivery to any internationally recognized overnight delivery service, or (iv) seven (7) days after it is deposited in the India Postal Services, as a postage prepaid, certified or registered mail. Each such notice will be sent to the respective parties at the address first indicated herein.

20. Successors and Assigns:

This agreement shall be binding upon and inure to the benefit of the Parties and their respective successors and assigns.

21. Compliance with Direction:

The Supplier shall comply with the directions issued from time to time by the VC & MD, APSCSCL while discharging the duties under this agreement.

22. Waiver:

No waiver of any term, provision or condition of this agreement shall be effective unless in writing, signed by the Party against which such waiver is sought to be enforced, and no such waiver shall be deemed to be or construed as a further or continuing waiver of any such term, provision or condition or as a waiver of any other term, provision or condition of this agreement, unless specifically so stated in such written waiver.

23. Amendment:

This agreement may not be amended, changed or modified in any manner except by an instrument in writing signed by a duly authorized representative of each Party. Any Products, services and/or other items provided or performed pursuant to any type of amendment shall be deemed provided and/or performed based on all applicable

provisions of this agreement. Any Exhibits attached to this agreement form an integral part of this agreement and are incorporated in this agreement by reference.

APSCSCL reserves the right to change any bid condition of any item even after inviting the bids, with prior notification to the bidders. Notwithstanding anything mentioned herein above, the Corporation shall have the discretionary power to amend any clause/s in this document (or) to take any decision on the matter under this document with prior notice to the bidder/s.

24. Counterparts:

This agreement may be executed in one or more counterparts, all of which shall be considered one and the same agreement and shall become effective when originally signed by both of the Parties.

25. Interpretation:

In case of any ambiguity or dispute regarding interpretation of any clause(s) of this tender document, VC & MD, APSCSCL's interpretation will be treated as final and binding.

26. Entire Agreement:

This agreement, including any exhibits and schedule hereto, contains the entire agreement and understanding between the parties, and supersedes any and all prior agreements, arrangements and understandings, relating to the subject matter hereof. There are no written and oral agreements, understandings, representations or warranties between the Parties other than those set forth or referred to in this agreement. No supplement, amendment, alteration, modification or waiver of this agreement shall be binding unless agreed to in writing by the Parties.

27. Independent Relationship:

This agreement does not constitute a party as the legal representative of the other for any purpose whatsoever. Neither Party is granted any right or authority to assume or to create any obligation or responsibility, express or implied, on behalf or in the name of the other, unless otherwise specifically agreed upon in writing in this agreement or any later agreement.

28. Forgery of Signatures:

The Supplier or his/her/their representative should submit the bills along with acknowledgements of concerned Corporation representative and the acknowledgements shall tally with the specimen signatures available with the Corporation. If it is found that any of the signature is forged or signed by some other person of the Supplier / representative, the bill is liable for cancellation apart from recovery of liquidated damages from the Security Deposit.

29. Loss Sustained by Corporation:

The Supplier shall indemnify the Corporation for any loss or damage sustained by it due to the improper performance of the work by the Supplier under this agreement. Such loss sustained by the Corporation shall be recovered from the bills payable to the Supplier and from the Security Deposit furnished by the supplier under the agreement, or under any other agreements of the Supplier with the Corporation. If the above sums not sufficient to cover the full amount recoverable, the Supplier shall pay the Corporation on demand the balance amount due. Otherwise, the Corporation is at liberty to recover the amount due under Revenue Recovery Act.

30. General:

This agreement, including any exhibits and schedules hereto, contains the entire agreement and understanding between the Parties, and supersedes any and all prior agreements, arrangements and understandings, relating to the subject matter hereof. There are no written or oral agreements, understandings, representations or warranties between the Parties other than those set forth or referred to in this agreement. No supplement, amendment, alteration, modification or waiver of this agreement shall be binding unless agreed to in writing by the Parties.

31. Force Majeure:

The terms and conditions hereof shall be subject to force majeure. Neither the Corporation nor the Supplier shall be considered in default in the performance of their respective obligations herein above if such performance is prevented or delayed because of act of God, War, Flood, Hostilities, Revolution, Civil Commotion, Official Strike, Epidemic, Accident or Fire, or because of Law and Order Proclamation, regulation or ordinance of any Govt. of any Subdivision thereof or local authority. The Supplier shall be entitled to the benefit of this clause only if he informs in writing of the circumstances

amounting to force majeure to the Corporation for each consignment/ dispatch separately within 48 hours of the happening thereof by email and fax immediately followed by a confirmatory letter sent by Regd. Post Acknowledgment due. In the event of the Supplier pleading any ground as constituting force majeure, the opinion of the management of the Corporation on that behalf alone shall prevail and, if in the opinion of the management, the grounds pleaded by the Supplier do not amount to force majeure, then Supplier shall not be entitled to plead the same and or claim any relief under this clause.

32. Severability:

If any term, covenant or condition of this agreement or the application thereof to any person or circumstance (other than a term, covenant, condition or application which affects the essence of this agreement) shall, to any extent, be invalid or unenforceable, the remainder of this agreement, or the application of such term, covenant or condition to those persons or circumstances other than those as to which it has been held invalid or unenforceable, shall not be affected thereby, and each term, covenant and condition of this agreement shall be valid and enforceable to the complete extent permitted by law.

33. Resolution of Disputes:

- a. In case of any disputes relating to this tender including the interpretation of any of the Clause/Clauses of the tender, the matter shall be referred to VC & MD, APSCSCL
- b. In case, if disputes are not resolved then, the matter may be referred to Commissioner of Civil Supplies, Government of Andhra Pradesh who will be the appellate authority.
- c. In case of any disputes still not resolved and which are relating to supply of Mobile Dispensing Units including the interpretation of any of the Clause/Clauses of this tender, the matter shall be referred to a sole arbitrator not less than the rank of Secretary to Government of Andhra Pradesh, appointed by the Government. The remuneration for the arbitrator shall be fixed by the Government. The arbitration shall be held in the place where the Head Office of APSCSCL situated, and the decision of the arbitrator shall be final and binding on both parties to the arbitration. The arbitration will be conducted in accordance with arbitration and conciliation Act, 1996.

- d. The Supplier shall prefer a demand, if any, in writing to the VC & MD, APSCSCL for arbitration in respect of any claim under this agreement within three months from the date of termination or completion of the agreement, failing which the demand shall be deemed to have been waived absolutely time barred and the Corporation shall be discharged and released of all liabilities under this agreement in respect of such demand.
- e. On receipt of a demand from the Supplier within the prescribed time, disputes and differences arising out of or in any way touching or concerning this agreement, except such matters, the decision of which is expressly provided for in the agreement shall be referred to the Arbitration as per Arbitration and Conciliation Act, 1996.
- f. The Arbitrator(s) shall give separate award in respect of each dispute or difference referred to him.

34. Indemnity:

- a. The Supplier shall indemnify, defend, save and hold harmless the Corporation and its officers, servants, agents, Government Instrumentalities and Government owned and/or controlled entities/enterprises, (the “Authority Indemnified Persons”) or any and all suits, proceedings, actions, demands and claims from third parties for any loss, damage, cost and expense of whatever kind and nature, whether arising out of any breach by the bidder of any of its obligations under this RFP or any related document or on account of any defect or deficiency in the provision of services by the Supplier or from any negligence of the Supplier under contract or tort or on any other ground whatsoever, except to the extent that any such suits, proceedings, actions, demands and claims have arisen due to any negligent act or omission, or breach or default of this Agreement on the part of the Authority Indemnified Persons.
- b. Without limiting the generality, the Supplier shall fully indemnify, hold harmless and defend the Corporation and the Corporation Indemnified Persons from and against any and all loss and/or damages arising out of or with respect to:
 - i. failure of the Supplier to comply with Applicable Laws and Applicable Permits;
 - ii. payment of taxes, levies, fees and any other statutory dues required to be made by the bidder in respect of the income or other taxes of the Supplier

contractors and representatives; or

- iii. non-payment of amounts due as a result of materials or services furnished to the Supplier or any of its contractors which are payable by the Supplier or any of its contractors.

35. Assignment:

Neither Party may assign this agreement to a third party without the consent of the other expressed in writing.

36. Observance of Law:

The Supplier shall be bound by all laws, order, et., in force or issued by the Central or State Government from time to time and shall be solely liable for any penal consequences that may incur due to violation by the Supplier of any law, orders, etc., in force.

37. Jurisdiction:

All Civil suits arising under this agreement should be subject to the jurisdiction of the City Civil Courts where APSCSCL Head Office situated only.

Annexure 1 – Tentative District-wise requirement of Mobile Dispensing Units:

District	No of Mobile Dispensing Units
SRIKAKULAM	526
VIZIANAGARAM	456
VISAKHAPATNAM	766
EAST GODAVARI	1040
WEST GODAVARI	795
KRISHNA	805
GUNTUR	920
PRAKASAM	634
NELLORE	566
KADAPA	515
KURNOOL	754
ANANTAPUR	761
CHITTOOR	722
Total	9260

Annexure 2 – Format of Turnover Certificate:

(To be issued on the Letter Head of CA Firm)

This is to certify that the following particular of M/s

_____ are true and correct as per the information and explanation provided to us and to the best of our knowledge and belief.

Financial Year	Gross Turnover (INR)
2017 – 18	
2018 – 19	
2019 – 20	

Place:

Date:

Signature

Name and Regn No. of CA Firm

Name and Membership No. member certifying

Annexure 3 – Format of Affidavit:

Rs. 100/- NON-JUDICIAL STAMP (Notarized)

Bid Ref. No: _____,

Dt: _____

SELF DECLARATION

Certified that _____ / the firm / company / partnership or any other firm / company in which the bidder is a partner / shareholder has not been blacklisted / debarred / delisted from participating in bids / contracts on the date of opening of the bid either in individual capacity of the proprietor or in any firm / centre in which the proprietor/s is / are partner by AP State Government or by any undertaking of State or Central Government. The Firm will immediately inform to APSCSCL in case of any change in the situation any time here in after.

Further, I am authorized to sign the affidavit on behalf of M/s ----- in my capacity as -----.

That the financial condition status of the firm is sound.

Above information is true to my knowledge and belief and is based on facts

(Signature with Seal of the Organization)

Name of the Authorized Signatory:

Name of the Bidding Organization:

Address of the Bidding Organization:

Date:

Annexure 4 – Format for Details of Authorized Service Centres:

Bidder to provide the details of the Authorized Service Centers in the State.

Authorization Letter for all the Service Centers mentioned as part of this Annexure to be provided at the time of signing of Supplier’s Agreement.

District	Revenue Division	Address & Contact Details of Authorized Service Centers

Annexure 5 – Price Break-up of Financial Bid:

Component	% of Financial Bid Price
Price of Base Vehicle (4-Wheeler Mini Truck)	
Price of other components (Cargo body fabrication, weighing bucket, GST and taxes, registration fee, permit, comprehensive vehicle insurance for one year, transport/freight charges etc.)	
Total	100%

Note: Bidders should not provide the price. Only notional percentage split of the final price is to be provided.

VC & MANAGING DIRECTOR

Pujari Anand Rao, M.Tech
Chief Engineer
SWACHHA ANDHRA CORPORATION
MA&UD Dept., GoAP
URL : www.sac.ap.gov.in
Email:
ceswachhandhra@gmail.com



H.No.54-16-1/14/D, 3rd Floor,
Road No.2, Central Excise Colony,
Andhra Loyal College Road,
Vijayawada-520008. A.P.
Telefax: 0866 2456708

Lr.No.5/SAC/CE/APSCSCL/MDU/2020-21, Dt.28-08-2020.

To
The Vice Chairman & Managing Director,
Andhra Pradesh State Civil Supplies Corporation Ltd.,
Regd. Office:10-152/1, Sri Sai Towers,
Bandar Road, Kanuru,
Vijayawada – 520007.

Madam,

Sub: APSCSCL – PDS – Alternative Distribution Model for door delivery of PDS Rice – Appointment of team for evaluation of Mobile Dispensing Units at field level – Assistance of Chief Engineer, O/o Swachh Andhra Corporation, Vijayawada - Requested – Reg.- Reg.

- Ref:1. G.O. Rt. No.43 of Consumer Affairs, Food and Civil Supplies (CS. I), Dt.29-07-2020.
2. CCS proceedings No.CCS.Ref.No.PDSII(I)/1025/17/2020 dated: 13-07-2020
3.G.O. Ms. No.10, Consumer Affairs, Food & CS Dept, Dt. 24-08-2020.
4. Lr. No. PDS.3/32/MDU/2020, Dt. 26.08.2020 from the VC&MD, APSCSCL, Vijayawada.

The Government of Andhra Pradesh, vide reference 1st cited, have taken a decision on distribution of essential commodities under PDS at the doorstep of cardholders. To examine the feasibilities, the Government has formed a committee with Group of Ministers to examine various issues related to Door Delivery of Rice. Accordingly, various meetings were conducted with the Group of Ministers and it was proposed to try distribution of ECs through alternate Model using Mobile Dispensing Units (MDUs).

As cited vide 2nd reference, a Technical Committee was constituted to compare and assess the suitability of Tractor Trolleys, Three Wheeler Mini Trucks and Four Wheeler Mini Trucks and recommend the most suitable MDU for last mile distribution along with suitable validations and technical specifications. The Committee conducted trial runs of various prototypes in the Urban, Semi-urban and Rural areas and finalized Four Wheeler Mini Trucks as the most suitable option and recommended the technical specifications.

Vide reference 3rd cited in G.O. Ms. No. 10, dated 26-08-2020, administrative approval has been accorded by the Ex-Officio Secretary to Government, Consumer Affairs, Food & Civil Supplies Department for releasing the Request for Proposal for purchase of Four Wheeler Mini Trucks with approved technical specifications.

In this connection, the most suitable Mobile Dispensing Units (MDUs) are to be recommended along with technical specifications for last mile distribution of ECs under PDS through Village/ Ward Secretariats.

Vide reference 4th cited, The Vice Chairman & Managing Director, APSCSCL, Vijayawada requested the Chief Engineer, O/o Swachh Andhra Corporation, Vijayawada to give technical approval on the designs of Mobile Dispensing Units with suggestions if any at the earliest for finalizing the most suitable MDUs for Door step Delivery of ECs to the card holders as per rules and regulations.

Gone through the designs of Mobile Dispensing Units and Technical Specifications and here with enclosing the approved Technical Specifications for the Chassis and the Cargo body to be built on the Chassis.

Encl: 1. Technical Specifications of
Mobile Dispensing Unit

Yours Sincerely

28/08/2020

Chief Engineer

SWACHHA ANDHRA CORPORATION

Technical Specifications of Mobile Dispensing (Food Grain) Distribution Van	
Chassis Specifications	
Engine	Minimum 2 Cylinder BS VI
Engine Capacity (in cc)	Minimum 694
Engine Power (in HP)	Minimum 20 HP
Brakes	Disc/Drum Brakes
No. of Tyres	4
Drive	Right Hand Side
Permissible GVW	Minimum 1600 Kg
Pay Load	Minimum 740 Kgs
Cargo Tray Size (LxW) (in mm)	Minimum 2183 x 1488
Ground Clearance (in mm)	Minimum 160
Wheel Base (in mm)	Minimum 1950
Wheel Size (in inches)	Minimum 12
Overall Width (in mm)	Minimum 1500
Overall Length (in mm)	Minimum 3800
Fuel Type	Petrol
Cargo Body Specifications	
Body Type	Chassis Mounted Body as per Specification below
Body Dimensions	Minimum Specifications / Criteria
External Length (in mm) (Excluding canopy and rear door in closed condition)	2175 +/- 15
External Width (in mm) (Excluding rain gutter)	1470 +/- 10
External Height (in mm)	1820 +/- 10
LH Loading Door (HxW) (in mm)	1670 x 1070 +/- 10
LH Distribution Door (HxW) (in mm)	1670 x 610 +/- 10
Rear Upper Flap (WxH) (in mm)	1370 x 1060 +/- 10
Rear Lower Flap (WxH) (in mm)	1370 x 610 +/- 10
Material Specifications	Minimum Specifications / Criteria
Floor Panel	OE corrugated floor/flat panel with adequate reinforcement for body fabrication
Side Panel	1.2 mm GI/MS sheet
Front Panel	1.2 mm GI/MS sheet
Rear Panel	1.2 mm GI/MS sheet
Structure (in mm)	40 x 20 x 1.5 MS tube/hat section, 20 x 20 x 2 MS tube section
Rear Bottom Panel	Chequered plate on rear bottom panel
Beading on doors for Water Proofing	U Profile EPDM rubber bulb beading
Electricals	Minimum Specifications / Criteria
Side Lamps	04 Nos LED lamps of reputed make. BIS Standard
Inside Lamps	02 Nos LED lamps of reputed make. BIS Standard
Control switch for exterior lights	Switch for all exterior lights at Driver's cabin
Control switch for interior lights	Switch for all interior lights at Driver's cabin
Charging point for Weighing Scale	01 No - Round female connector with Centre Positive (DC Powered)
Plug Point with Switch	01 No - 2 Pin Plug Point (DC Powered)
Mini fan	01 No - Directed towards foldable seat - Reputed make. BIS Standard

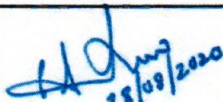
 28/09/2020
 CE, JAC

Attested A Surya Kumari

V.C. & Managing Director
 A.P. State Civil Supplies Corporation Ltd.
 VIJAYAWADA-520 007.

Public Address System	Speaker at front of the vehicle at the top Siren switch for speaker inside Driver cabin Announcement mike to be provided near foldable seat
Standard Parts	Minimum Specifications / Criteria
Foldable Seat	01 No - Minimum 40 density foam cushion seat
Gas Stay Spring - Rear upper flap	02 Nos (1 on each side) Minimum 20 Kg lift capacity
Door Chain - Rear lower flap	02 Nos (1 on each side) SS chain with minimum 4 mm thickness Minimum support capacity of 200 Kgs
Side Door locks	02 Nos - Heavy duty MS latch door lock with door handle
Rear Door inside locks	02 Nos - Tower bolts MS from reputed make
Grab Handle	Plastic grab handles for doors
Hook for Hanging Weighing Scale	01 No - 100 Kg capacity movable along with horizontal directional
Rubber Floor Mat	01 No - 80 x 40 x 2 (mm) tubular reinforcement
Wind Deflector	Yes - FRP material
Footsteps	02 Nos - 1 each for Distribution door and Loading door 2-step MS tubular structure
Empty First Aid Box	01 No - Mounted on Centre Pillar between Distribution door and Loading door
Multipurpose Box (Cash Box)	01 No - Mounted on Centre Pillar between Distribution door and Loading door below First Aid Box
Mini Fire Extinguisher	01 No - 1 Kg Easy access mounting on floor near Centre Pillar between Distribution door and Loading door
Notice Board	01 No - Thick white acrylic sheet Top half of Distribution door with suitable mounting
Painting	Minimum Specifications / Criteria
Cargo Body	MS Body - CED coating with Stove Drying paint GI Body - Air drying PU paint with primer coat and suitable surface treatment
Quality Assurance	Minimum Specifications / Criteria
Rain Test	Self-assurance quality certificate for Rain test
Fully Built Vehicle Dimensions: - Minimum Specification	
Overall Length (in mm)	3800
Overall Width (in mm)(Including Rain C	1520 +/- 15
Overall Width (in mm)(Including ORVM	1850 ORVM to ORVM
Overall Height (in mm)	2480 +/- 15

//Approved//

[Signature]
28/08/2020
Chief Engineer

Swachha Andhra Corporation

Attested A Surya Kumar

V.C. & Managing Director
A.P. State Civil Supplies Corporation Ltd.
VIJAYAWADA-520 007.

Indicative Drawing of Vehicle

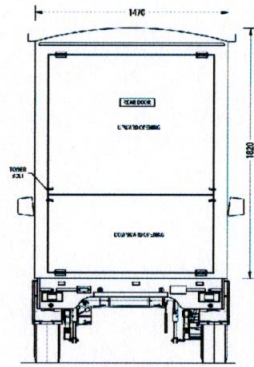

REAR VIEW

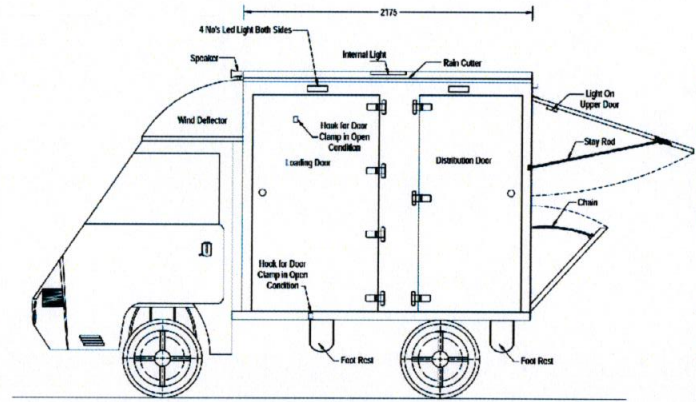

CO - DRIVER VIEW

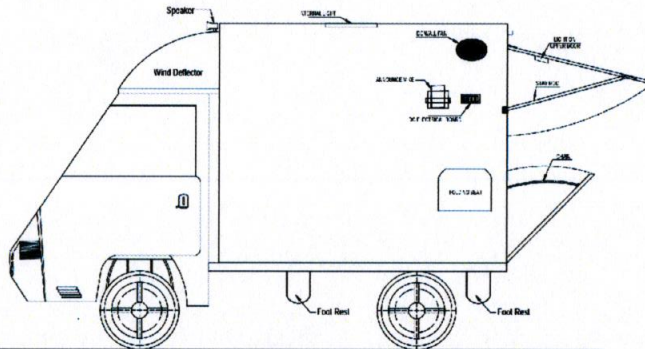

SECTION A-A

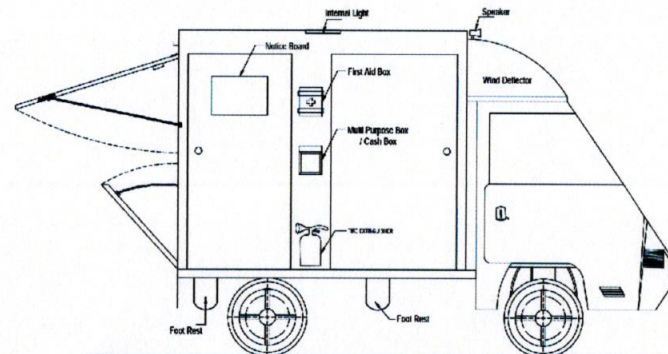

SECTION B-B

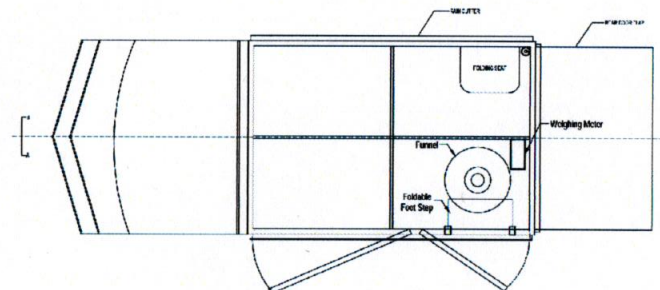

TOP VIEW

Approved/
[Signature]
 28/08/2020
 Chief Engineer
 Swachha Andhra Corporation

V.C. & Managing Director
 A.P. State Civil Supplies Corporation Ltd.
 VIJAYAWADA-520 007.

Attested A Subya Kumari

Technical Specifications of Mobile Dispensing (Food Grain) Distribution Van	
Chassis Specifications	
Engine	Minimum 2 Cylinder BS VI
Engine Capacity (in cc)	Minimum 694
Engine Power (in HP)	Minimum 20 HP
Brakes	Disc/Drum Brakes
No. of Tyres	4
Drive	Right Hand Side
Permissible GVW	Minimum 1600 Kg
Pay Load	Minimum 740 Kgs
Cargo Tray Size (LxW) (in mm)	Minimum 2183 x 1488
Ground Clearance (in mm)	Minimum 160
Wheel Base (in mm)	Minimum 1950
Wheel Size (in inches)	Minimum 12
Overall Width (in mm)	Minimum 1500
Overall Length (in mm)	Minimum 3800
Fuel Type	Petrol
Cargo Body Specifications	
Body Type	Chassis Mounted Body as per Specification below
Body Dimensions	Minimum Specifications / Criteria
External Length (in mm) (Excluding canopy and rear door in closed condition)	2175 +/- 15
External Width (in mm) (Excluding rain gutter)	1470 +/- 10
External Height (in mm)	1820 +/- 10
LH Loading Door (HxW) (in mm)	1670 x 1070 +/- 10
LH Distribution Door (HxW) (in mm)	1670 x 610 +/- 10
Rear Upper Flap (WxH) (in mm)	1370 x 1060 +/- 10
Rear Lower Flap (WxH) (in mm)	1370 x 610 +/- 10
Material Specifications	Minimum Specifications / Criteria
Floor Panel	OE corrugated floor/flat panel with adequate reinforcement for body fabrication
Side Panel	1.2 mm GI/MS sheet
Front Panel	1.2 mm GI/MS sheet
Rear Panel	1.2 mm GI/MS sheet
Structure (in mm)	40 x 20 x 1.5 MS tube/hat section, 20 x 20 x 2 MS tube section
Rear Bottom Panel	Chequered plate on rear bottom panel
Beading on doors for Water Proofing	U Profile EPDM rubber bulb beading
Electricals	Minimum Specifications / Criteria
Side Lamps	04 Nos LED lamps of reputed make. BIS Standard
Inside Lamps	02 Nos LED lamps of reputed make. BIS Standard
Control switch for exterior lights	Switch for all exterior lights at Driver's cabin
Control switch for interior lights	Switch for all interior lights at Driver's cabin
Charging point for Weighing Scale	01 No - Round female connector with Centre Positive (DC Powered)
Plug Point with Switch	01 No - 2 Pin Plug Point (DC Powered)
Mini fan	01 No - Directed towards foldable seat - Reputed make. BIS Standard

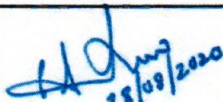
 28/09/2020
 CE, JAC

Attested A Surya Kumari

V.C. & Managing Director
 A.P. State Civil Supplies Corporation Ltd.
 VIJAYAWADA-520 007.

Public Address System	Speaker at front of the vehicle at the top Siren switch for speaker inside Driver cabin Announcement mike to be provided near foldable seat
Standard Parts	Minimum Specifications / Criteria
Foldable Seat	01 No - Minimum 40 density foam cushion seat
Gas Stay Spring - Rear upper flap	02 Nos (1 on each side) Minimum 20 Kg lift capacity
Door Chain - Rear lower flap	02 Nos (1 on each side) SS chain with minimum 4 mm thickness Minimum support capacity of 200 Kgs
Side Door locks	02 Nos - Heavy duty MS latch door lock with door handle
Rear Door inside locks	02 Nos - Tower bolts MS from reputed make
Grab Handle	Plastic grab handles for doors
Hook for Hanging Weighing Scale	01 No - 100 Kg capacity movable along with horizontal directional
Rubber Floor Mat	01 No - 80 x 40 x 2 (mm) tubular reinforcement
Wind Deflector	Yes - FRP material
Footsteps	02 Nos - 1 each for Distribution door and Loading door 2-step MS tubular structure
Empty First Aid Box	01 No - Mounted on Centre Pillar between Distribution door and Loading door
Multipurpose Box (Cash Box)	01 No - Mounted on Centre Pillar between Distribution door and Loading door below First Aid Box
Mini Fire Extinguisher	01 No - 1 Kg Easy access mounting on floor near Centre Pillar between Distribution door and Loading door
Notice Board	01 No - Thick white acrylic sheet Top half of Distribution door with suitable mounting
Painting	Minimum Specifications / Criteria
Cargo Body	MS Body - CED coating with Stove Drying paint GI Body - Air drying PU paint with primer coat and suitable surface treatment
Quality Assurance	Minimum Specifications / Criteria
Rain Test	Self-assurance quality certificate for Rain test
Fully Built Vehicle Dimensions: - Minimum Specification	
Overall Length (in mm)	3800
Overall Width (in mm)(Including Rain C	1520 +/- 15
Overall Width (in mm)(Including ORVM	1850 ORVM to ORVM
Overall Height (in mm)	2480 +/- 15

//Approved//

[Signature]
28/08/2020
Chief Engineer

Swachha Andhra Corporation

Attested A Surya Kumar

V.C. & Managing Director
A.P. State Civil Supplies Corporation Ltd.
VIJAYAWADA-520 007.

Indicative Drawing of Vehicle

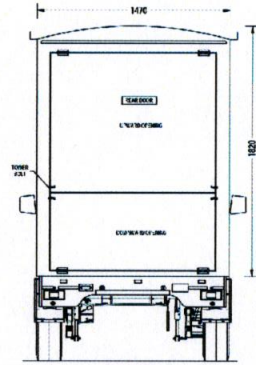

REAR VIEW

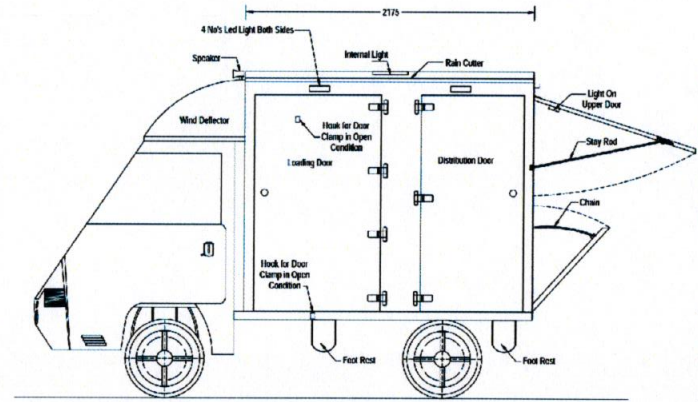

CO - DRIVER VIEW

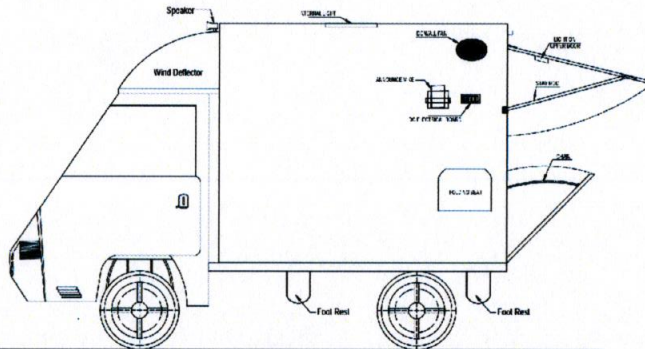

SECTION A-A

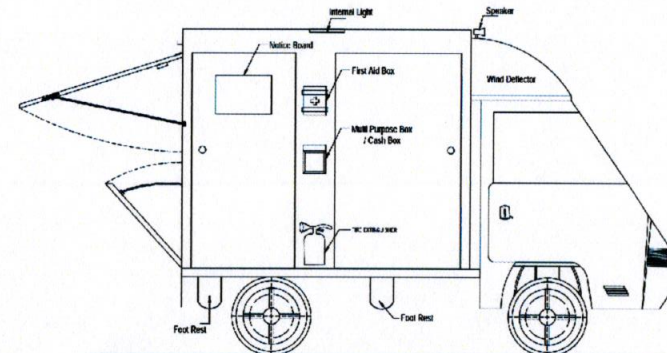

SECTION B-B

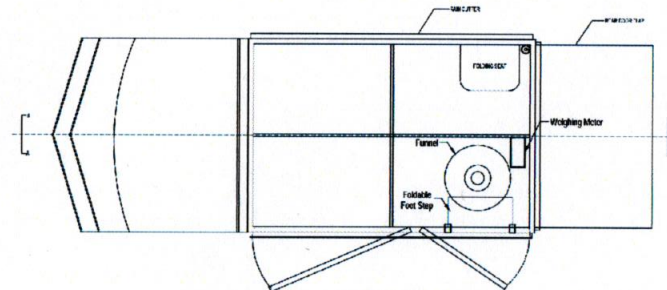

TOP VIEW

Approved/
A. Subya
28/08/2020
Chief Engineer
Swachha Andhra Corporation

V.C. & Managing Director
A.P. State Civil Supplies Corporation Ltd.
VIJAYAWADA-520 007.

Attested

A Subya Kumari